



---

European Organisation for Technical Approvals  
Europäische Organisation für Technische Zulassungen  
Organisation Européenne pour l'Agrément Technique

---

**ETAG 034**

**Edition April 2012**

**GUIDELINE FOR EUROPEAN TECHNICAL APPROVAL**  
**of**  
**KITS FOR EXTERNAL**  
**WALL CLADDINGS**

**Part I : VENTILATED CLADDING KITS COMPRISING CLADDING  
COMPONENTS AND ASSOCIATED FIXINGS**

---

**E O T A ©**

Kunstlaan 40 Avenue des Arts  
B - 1040 BRUSSEL

# TABLE OF CONTENTS

<b>FOREWORD.....</b>	<b>6</b>
BACKGROUND OF THE ETAG .....	6
REFERENCE DOCUMENTS .....	6
UPDATING CONDITIONS .....	6
<b>SECTION ONE: INTRODUCTION.....</b>	<b>7</b>
<b>1. PRELIMINARIES.....</b>	<b>7</b>
1.1 LEGAL BASIS.....	7
1.2 STATUS OF ETA-GUIDELINES.....	7
<b>2 SCOPE.....</b>	<b>8</b>
2.1 SCOPE.....	8
2.2 USE CATEGORIES, PRODUCTS FAMILIES, KITS.....	10
2.2.1 <i>Claddings families</i> .....	10
2.2.2 <i>Use categories</i> .....	16
2.3 ASSUMPTIONS.....	16
<b>3 TERMINOLOGY.....</b>	<b>16</b>
3.1 COMMON TERMINOLOGY AND ABBREVIATIONS.....	16
3.2 SPECIFIC TERMINOLOGY.....	16
3.2.1 <i>Cladding kit</i> .....	16
3.2.2 <i>Substrate</i> .....	16
3.2.3 <i>Subframe</i> .....	17
3.2.4 <i>Cladding element</i> .....	17
3.2.5 <i>Cladding fixing</i> .....	17
3.2.6 <i>Subframe fixing devices</i> .....	17
3.2.7 <i>Ancillary materials</i> .....	17
3.2.8 <i>Cavity barrier (compartmentation of air space)</i> .....	18
3.2.9 <i>Air space</i> .....	18
3.2.10 <i>Ventilated air space</i> .....	18
3.2.11 <i>Breather membrane</i> .....	18
<b>SECTION TWO: GUIDANCE FOR THE ASSESSMENT OF THE FITNESS FOR USE.....</b>	<b>19</b>
<b>GENERAL NOTES:.....</b>	<b>19</b>
<b>4 REQUIREMENTS.....</b>	<b>20</b>
4.1 ER1: MECHANICAL RESISTANCE AND STABILITY.....	22
4.2 ER2: SAFETY IN CASE OF FIRE.....	22
4.2.1 <i>Reaction to fire</i> .....	22
4.2.2 <i>Fire resistance</i> .....	22
4.3 ER3: HYGIENE, HEALTH AND ENVIRONMENT.....	22
4.3.1 <i>Indoor environment, dampness</i> .....	22
4.3.2 <i>Outdoor environment</i> .....	23
4.4 ER4: SAFETY IN USE.....	24
4.5 ER5: PROTECTION AGAINST NOISE.....	25
4.6 ER6: ENERGY ECONOMY AND HEAT RETENTION.....	25
4.7 ASPECTS OF DURABILITY AND SERVICEABILITY.....	25
5.1 ER1: MECHANICAL RESISTANCE AND STABILITY.....	28
5.2 ER2: SAFETY IN CASE OF FIRE.....	28
5.2.1 <i>Reaction to fire in intended used</i> .....	28
5.2.2 <i>Reaction to fire on back side</i> .....	29
5.2.3 <i>Fire resistance</i> .....	29
5.3 ER3: HYGIENE, HEALTH AND THE ENVIRONMENT.....	29
5.3.1 <i>Watertightness of joints (protection against driving rain)</i> .....	29
5.3.2 <i>Water permeability of cladding element (resistance to water diffusion)</i> .....	31
5.3.3 <i>Water vapour permeability</i> .....	31
5.3.4 <i>Drainability</i> .....	31
5.3.5 <i>Content and/or release of dangerous substances</i> .....	32

5.3.5.1	Content and/or release of dangerous substances in the product .....	32
5.3.5.2	Compliance with the applicable regulations .....	33
5.3.5.3	Application of the precautionary principle .....	33
5.4	ER4 : SAFETY IN USE .....	34
5.4.1	<i>Wind load resistance</i> .....	34
5.4.1.1	Wind suction test .....	34
5.4.1.2	Wind pressure test .....	39
5.4.2	<i>Mechanical test</i> .....	39
5.4.2.1	Family A .....	40
5.4.2.1.1	Pull-through resistance of cladding element .....	40
5.4.2.1.2	Pull-through resistance under shear loads .....	42
5.4.2.2	Family B .....	43
5.4.2.2.1	Axial tension test with varying diameter of support .....	43
5.4.2.2.2	Shear test .....	44
5.4.2.2.3	Tests with combined tension and shear loading .....	44
5.4.2.3	Family C .....	45
5.4.2.3.1	Resistance of grooved cladding element .....	45
5.4.2.3.2	Resistance of stone at the dowel hole .....	46
5.4.2.3.3	Resistance to vertical load .....	46
5.4.2.3.4	Pull-through resistance of fixings from profiles .....	47
5.4.2.4	Family D .....	47
5.4.2.4.1	Pull-through resistance of cladding element .....	47
5.4.2.4.2	Resistance of grooved cladding element .....	48
5.4.2.4.3	Pull-through resistance under shear loads .....	48
5.4.2.5	Family E .....	48
5.4.2.5.1	Pull-through resistance of cladding element .....	48
5.4.2.5.2	Pull-through resistance under shear loads .....	48
5.4.2.6	Family F .....	49
5.4.2.6.1	Resistance of metal clip .....	49
5.4.2.6.2	Resistance to vertical load .....	49
5.4.2.7	Family G .....	50
5.4.2.7.1	Resistance of slot .....	50
5.4.2.8	Family H .....	50
5.4.3	<i>Resistance to horizontal point loads</i> .....	50
5.4.4	<i>Impact resistance</i> .....	51
5.4.4.1	Resistance to hard body impact .....	51
5.4.4.2	Resistance to soft body impact .....	51
5.4.5	<i>Resistance to seismic actions</i> .....	52
5.4.6	<i>Hygrothermal behaviour</i> .....	52
5.5	ER5 PROTECTION AGAINST NOISE .....	53
5.6	ER6 ENERGY ECONOMY AND HEAT RETENTION .....	53
5.7	ASPECTS OF DURABILITY AND SERVICEABILITY .....	53
5.7.1	<i>Pulsating load</i> .....	53
5.7.2	<i>Dimensional stability of external cladding</i> .....	54
5.7.3	<i>Immersion in water</i> .....	54
5.7.4	<i>Freeze-thaw</i> .....	54
5.7.5	<i>Chemical and biological resistance</i> .....	55
5.7.6	<i>Corrosion</i> .....	56
5.7.6.1	Cladding element made of steel, steel alloys or stainless steel .....	56
5.7.6.2	Cladding element made of aluminium or aluminium alloys .....	56
5.7.6.3	Cladding fixings .....	57
5.7.7	<i>UV radiation</i> .....	57
<b>6</b>	<b>ASSESSING AND JUDGING THE FITNESS FOR USE .....</b>	<b>59</b>
6.1	MECHANICAL RESISTANCE AND STABILITY .....	60
6.2	SAFETY IN CASE OF FIRE .....	60
6.2.1	<i>Reaction to fire</i> .....	60
6.2.2	<i>Reaction to fire on rear side</i> .....	60
6.2.3	<i>Fire resistance</i> .....	61
6.3	HYGIENE, HEALTH AND THE ENVIRONMENT .....	61
6.3.1	<i>Watertightness of joints</i> .....	61
6.3.2	<i>Water permeability</i> .....	61
6.3.3	<i>Water vapour permeability</i> .....	61
6.3.4	<i>Drainability</i> .....	61
6.3.5	<i>Release of dangerous substances</i> .....	61
6.4	SAFETY IN USE .....	62

6.4.1	<i>Wind load resistance</i> .....	62
6.4.1.1	Wind suction.....	63
6.4.1.2	Pressure .....	63
6.4.2	<i>Mechanical resistance</i> .....	63
6.4.2.1	Family A.....	63
6.4.2.1.1	Pull through resistance under shear loads .....	63
6.4.2.2	Family B .....	63
6.4.2.3	Family C .....	63
6.4.2.3.1	Resistance of grooved cladding element .....	63
6.4.2.3.2	Resistance of stone at dowel hole .....	63
6.4.2.3.3	Resistance of vertical load .....	64
6.4.2.3.4	Pull through resistance of fixings from profiles .....	64
6.4.2.4	Family D.....	64
6.4.2.4.1	Through cladding element.....	64
6.4.2.4.2	Resistance of grooved cladding element .....	64
6.4.2.4.3	Pull through resistance under shear loads .....	64
6.4.2.5	Family E .....	64
6.4.2.5.1	Through cladding element.....	64
6.4.2.5.2	Pull through resistance under shear loads .....	64
6.4.2.6	Family F .....	64
6.4.2.6.1	Resistance of metal clip .....	64
6.4.2.6.2	Resistance of vertical load .....	64
6.4.2.7	Family G.....	64
6.4.2.8	Family H.....	64
6.4.3	<i>Resistance to horizontal point loads</i> .....	65
6.4.4	<i>Impact resistance – shatter properties</i> .....	65
6.4.5	<i>Resistance to seismic actions</i> .....	66
6.4.6	<i>Hygrothermal behaviour</i> .....	66
6.5	PROTECTION AGAINST NOISE .....	66
6.6	ENERGY ECONOMY AND HEAT RETENTION.....	66
6.7	ASPECTS OF DURABILITY AND SERVICEABILITY .....	66
6.7.1	<i>Pulsating load</i> .....	66
6.7.2	<i>Dimensional stability of external cladding element</i> .....	66
6.7.3	<i>Immersion in water</i> .....	66
6.7.4	<i>Freeze-thaw</i> .....	66
6.7.5	<i>Chemical and biological attack</i> .....	67
6.7.6	<i>Corrosion</i> .....	67
6.7.7	<i>UV radiation</i> .....	67
<b>7</b>	<b>ASSUMPTIONS AND RECOMMENDATIONS UNDER WHICH THE FITNESS FOR USE OF THE PRODUCT IS ASSESSED</b> .....	<b>68</b>
7.1	DESIGN OF THE WORKS .....	68
7.2	EXECUTION OF THE WORKS .....	68
7.2.1	<i>Execution of the kit</i> .....	68
7.2.2	<i>Maintenance and repair of the works</i> .....	69
	<b>SECTION THREE: ATTESTATION OF CONFORMITY</b> .....	<b>70</b>
<b>8</b>	<b>EVALUATION AND ATTESTATION OF CONFORMITY AND CE MARKING</b> .....	<b>70</b>
8.1	SYSTEM OF ATTESTATION OF CONFORMITY.....	70
8.2	TASKS AND RESPONSIBILITIES OF THE MANUFACTURER AND NOTIFIED BODIES .....	71
8.2.1	<b>TASKS FOR THE MANUFACTURER</b> .....	71
8.2.1.1	Factory production control (All Systems of A/C).....	71
8.2.1.2	Testing of samples taken at the factory – Prescribed Test Plan (system 1).....	72
8.2.1.3	Declaration of Conformity (for all AoC systems).....	72
8.2.2	<b>TASKS OF THE MANUFACTURER OR THE NOTIFIED BODY: INITIAL TYPE TESTING</b> .....	72
8.2.3	<b>TASKS FOR THE NOTIFIED BODY</b> .....	73
8.2.3.1	Assessment of the factory production control - initial inspection and continuous surveillance.....	73
8.2.3.2	Certification.....	73
8.3	DOCUMENTATION.....	74
8.4	CE MARKING AND INFORMATION.....	76
	<b>SECTION FOUR: ETA CONTENT</b> .....	<b>77</b>
<b>9</b>	<b>THE ETA CONTENT</b> .....	<b>77</b>

9.1	THE ETA CONTENT .....	77
9.1.1	<i>Model ETA</i> .....	77
9.1.2	<i>Checklist for the issuing body</i> .....	77
9.1.3	<i>Note concerning dangerous substances</i> .....	78
9.1.4	<i>Identification</i> .....	79
<b>ANNEX A: COMMON TERMINOLOGY AND ABBREVIATIONS.....</b>		<b>80</b>
<b>ANNEX B: REFERENCE DOCUMENTS .....</b>		<b>84</b>
<b>ANNEX C: METHODS RELATED TO THE IDENTIFICATION OF THE PHYSICAL AND MECHANICAL CHARACTERISTICS OF CLADDING ELEMENT .....</b>		<b>90</b>
<b>ANNEX D: GENERAL TEST RESULTS STATISTICAL INTERPRETATION .....</b>		<b>92</b>
<b>ANNEX E: MOUNTING AND FIXING PROVISIONS FOR THE SBI TEST.....</b>		<b>93</b>

## FOREWORD

### *Background of the ETAG*

This Guideline has been drawn up by the EOTA Working Group 04.04/08 – Kits for external wall claddings.

The WG consisted of members from eight European countries (Belgium, France (Convenor), Germany, Slovakia, Slovenia, Poland, Czech Republic and the United Kingdom) and three European industrial organisations (EFFCM (European Federation of Fibre-Cement Manufacturers), EuPC (European Plastics Converters) and FEICA (Association of European Adhesives Manufacturers)).

The Guideline sets out the performance requirements for cladding kits for use as external wall claddings, the verification methods used to examine the various aspects of performance, the assessment criteria used to judge the performance for the intended use and the presumed conditions for the design and execution.

### *Reference documents*

Reference documents are referred to within the body of the ETAG and are subject to the specific conditions mentioned therein

The **list of reference documents** (mentioning the year of issue) for this ETAG is given in Annex B. When additional parts for this ETAG are written afterwards, they may comprise modifications to the list of reference documents applicable to that part.

### *Updating conditions*

The edition of a reference document given in this list is that which has been adopted by EOTA for its specific use.

When a new edition becomes available, this supersedes the edition mentioned in the list only when EOTA has verified or re-established (possibly with appropriate linkage) its compatibility with the guideline.

**EOTA Technical Reports** go into detail in some aspects and as such are not part of the ETAG but express the common understanding of existing knowledge and experience of the EOTA-bodies at that moment. When knowledge and experience is developing, especially through approval work, these reports can be amended and supplemented.

**EOTA Comprehension Documents** permanently take on board all useful information on the general understanding of this ETAG as developed when delivering ETA's by consensus among the EOTA members. Readers and users of this ETAG are advised to check the current status of these documents with an EOTA member.

EOTA may need to make alterations/corrections to the ETAG during its life. These changes will be incorporated into the official version on the EOTA website [www.eota.be](http://www.eota.be) and the actions catalogued and dated in the associated History File.

Readers and users of this ETAG are advised to check the current status of the content of this document with that on the EOTA website. The front cover will indicate if and when amendment has taken place.

# Section one: INTRODUCTION

---

## 1. PRELIMINARIES

### 1.1 Legal basis

This ETAG has been established in compliance with the provisions of the Council Directive 89/106/EEC (CPD) and has been established taking into account the following steps:

- issuing of the final mandate by the EC: 17/03/2003
- issuing of the final mandate by EFTA: 17/03/2003
- adoption of the Guideline by EOTA (Executive Commission) : 27/03/2008
- endorsement by the EC / EFTA: SCC opinion of 29/08/2008  
EC letter of 21/06/2012

This document is published by the Member States in their official language or languages according to Art 11/3 of the CPD.

No existing ETAG is superseded.

### 1.2 Status of ETA-guidelines

**A)** An ETA is one of two types of technical specifications in the sense of the EC 89/106 Construction Products Directive. This means that Member States shall presume that the approved products are fit for their intended use, i.e. they enable works in which they are employed to satisfy the Essential Requirements during an economically reasonable working life, provided that:

- The works are properly designed and built;
- The conformity of the products with the ETA has been properly attested.

**B)** This ETAG is a basis for ETA's, i.e. a basis for technical assessment of the fitness for use of a product for an intended use. An ETAG is not itself a technical specification in the sense of the CPD.

This ETAG expresses the common understanding of the Approval Bodies, acting together within EOTA, as to the provisions of the Construction Products Directive 89/106 and of the Interpretative Documents, in relation to the products and uses concerned, and is written within the framework of a mandate given by the Commission and the EFTA secretariat, after consulting the Standing Committee for Construction.

**C)** When accepted by the European Commission after consultation with the Standing Committee for Construction, this ETAG is binding for the issuing of ETA's for the products for the defined intended uses

The application and satisfaction of the provisions of an ETAG (examinations, tests and evaluation methods) leads to an ETA and a presumption of fitness of a product for the defined use only through an evaluation and approval process and decision, followed by the

corresponding attestation of conformity. This distinguishes an ETAG from a harmonized European Standard which is the direct basis for attestation of conformity.

Where appropriate, products which are outside of the precise scope of this ETAG may be considered through the approval procedure without guidelines according to art. 9.2 of the CPD.

The requirements in this ETAG are set out in terms of objectives and of relevant actions to be taken into account. It specifies values and characteristics, the conformity with which gives the presumption that the requirements set out are satisfied, wherever the state of the art permits and after having been confirmed as appropriate for the particular product by the ETA.

## **2 SCOPE**

### **2.1 Scope**

#### **General (Part I and II)**

This guideline covers kits for vertical exterior wall claddings consisting of an external cladding, mechanically fastened to a framework (specific to the kit or not), which is fixed to the external wall of new or existing buildings (retrofit). An insulation layer is usually fixed on the external wall.

The substrate walls are made of masonry (clay, concrete or stone), concrete (cast on site or as prefabricated panels), timber or metal frame.

Insulation material is defined in accordance with an EN standard or an ETA.

Between the cladding elements and the insulation layer or the external wall accordingly, there is an air space which shall always be drained and may be ventilated or not.

The cladding elements can be made of e.g. wood based panels, plastic, fibre cement, fibre reinforced cement, concrete, metal, laminate panels, stone, ceramic or terra cotta tiles.

The cladding elements are attached to the external wall using a subframe, which is made of timber or metal (steel, stainless steel or aluminium).

The cladding elements are usually assembled according to a specific technical design for joints and construction discontinuities, which forms part of the product description.

The claddings are non load-bearing construction elements. They do not contribute to the stability of the wall on which they are installed. The claddings will normally contribute to durability of the works by providing enhanced protection from the effect of weathering. They are not intended to ensure airtightness of the building structure.

The cladding kits do not contain windows or doors.

This guideline does not cover external wall cladding kits where the cladding is:

- Made of self-supporting double skin faced insulating panels according to EN 14509 (sandwich panels),
- Made of composite panels not covered by ETAG 016 or for which an assessment method is not specified in ETAG 016 nor in a related specific TR,



- Made with a render sprayed in situ on metal mesh,
- Made of panels covered by a render applied in situ.

This guideline does not cover cladding kits where the cladding is bonded directly to the subframe.

This guideline does not cover curtain walls which are covered by EN 13830.

This guideline does not cover external wall cladding made of glass and agglomerated stone. These products can be covered by CUAPs based on this guide with additional requirements.

This guideline does not deal with external cladding in contact with the ground.

The manufacturer shall define a complete kit but can provide/produce one or some components of the defined kit.

When a manufacturer delivers together all the components of a kit for external wall cladding, this ETAG applies.

When only the cladding elements (without fixings) are placed on the market by the applicant (manufacturer), an ETA can be issued in accordance with this ETAG, only if the other components of the kit (e.g. fixings) are available on the market and specified in the ETA by the description of dimensions, material and performances of components. The manufacturer and trading reference of fixings may be indicated. In this case, all tests for granting the ETA shall be done with the specified fixings.

This guideline does not cover external suspended ceilings. All kits containing non vertical parts are excluded.

A kit is a special type of product; in this ETAG, therefore, 'product' is used as a synonym for 'kit'.

## **Part I**

Part I of the guideline covers only the external claddings and associated mechanical fixings intended to be used with a ventilated air space. Forming the kit are the cladding elements and their fixing devices (which fasten the cladding elements to the framework).

External wall claddings are considered as ventilated when the following criteria are fulfilled:

- The distance between the cladding elements and the insulation layer or the substrate accordingly (ventilation air space) amounts to at least 20 mm. This air space may be reduced locally to 5 to 10 mm depending on the cladding and the subframe, provided that it is verified that it does not affect the draining and/or ventilation function,
- Ventilation openings are envisaged, as a minimum, at the building base point and at the roof edge with cross-sections of at least 50 cm<sup>2</sup> per linear metre.

## **Part II**

Part II of the guideline covers the kit of all the components of claddings (external cladding element and their fixing devices, the subframe and their fixings to an external wall, and any insulation layer) intended to be used with an air space, ventilated or not.

## 2.2 Use categories, products families, kits

### 2.2.1 Claddings families

From the mechanical design, Claddings are differentiated according to the methods of fixing. See below (figure A to H) some examples of families.

Other exterior cladding kits may be assessed by appraisal of similarities with these families.

A- Cladding kit consisting of cladding elements mechanically fastened to the subframe by through fixing (e.g. nails, screws, rivets, ...) :

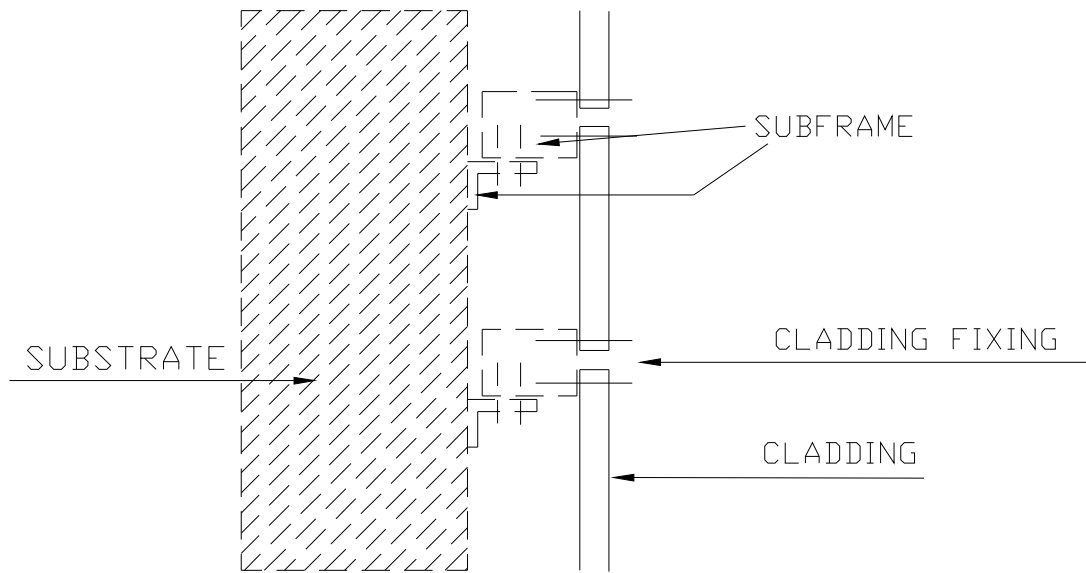

B- Cladding kit consisting of cladding elements mechanically fastened to the subframe by a specific anchor placed in an undercut hole and anchored by mechanical interlock (at least 4 anchors)°:

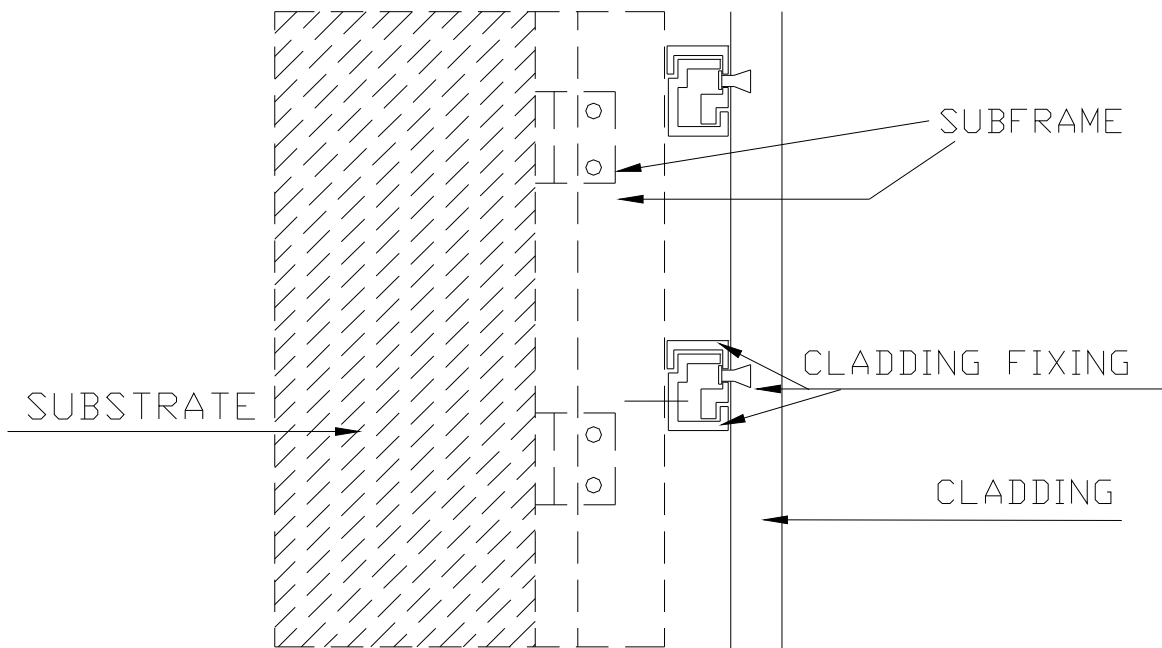

- C- Cladding kit consisting of cladding elements installed on a horizontal grid of metal rails or pins (e.g. dowel anchor), screwed to a vertical subframe

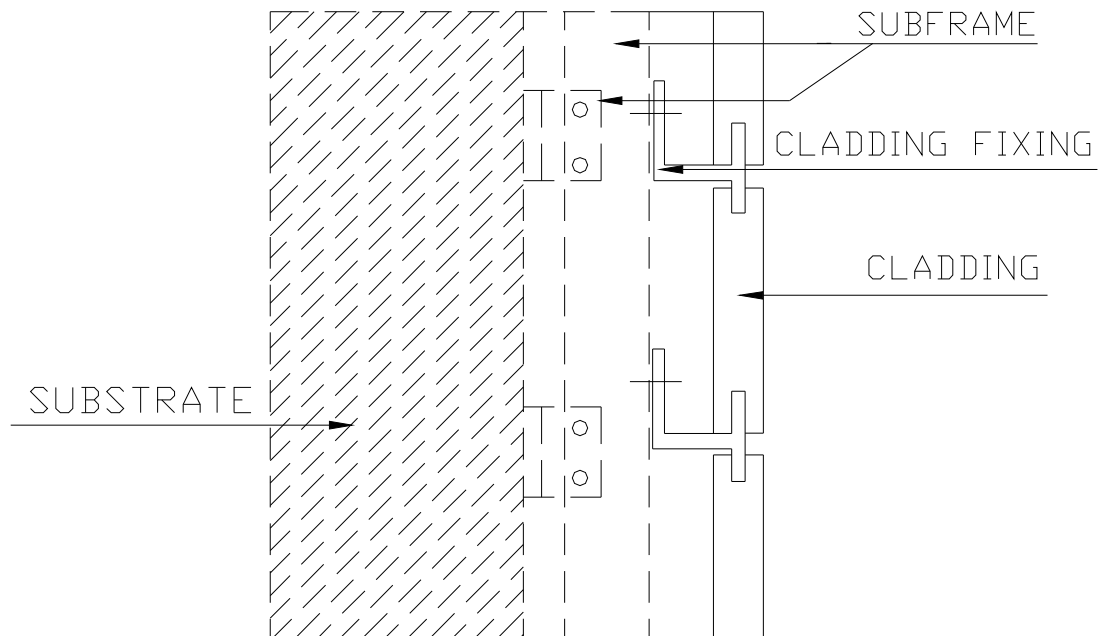

- D- Cladding kit consisting of cladding elements, integrated with adjacent elements by interlocking together at top and bottom with an overlap, fixed to the subframe by mechanical fixings positioned on the top edge and masked by the edge of the upper elements

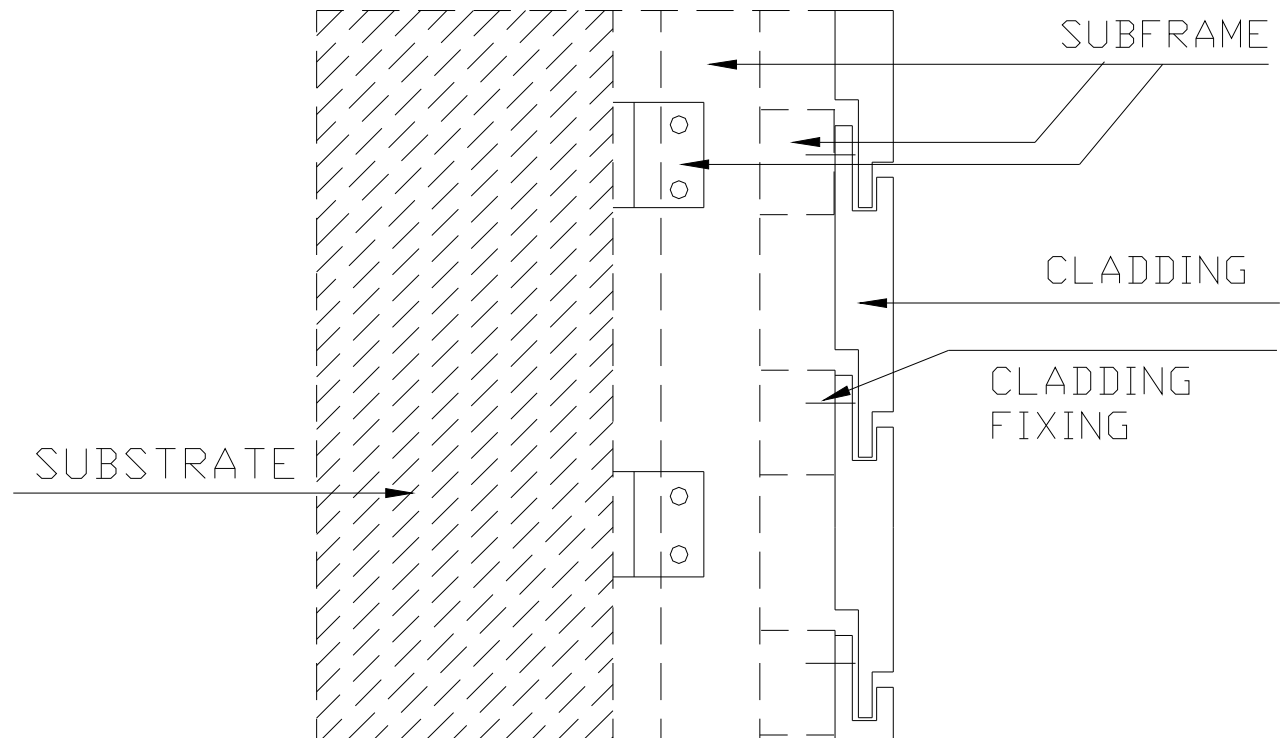

- E- Cladding kit consisting of cladding elements fixed to the subframe by mechanical fixings positioned on the top edge and masked by the edge of the upper plank

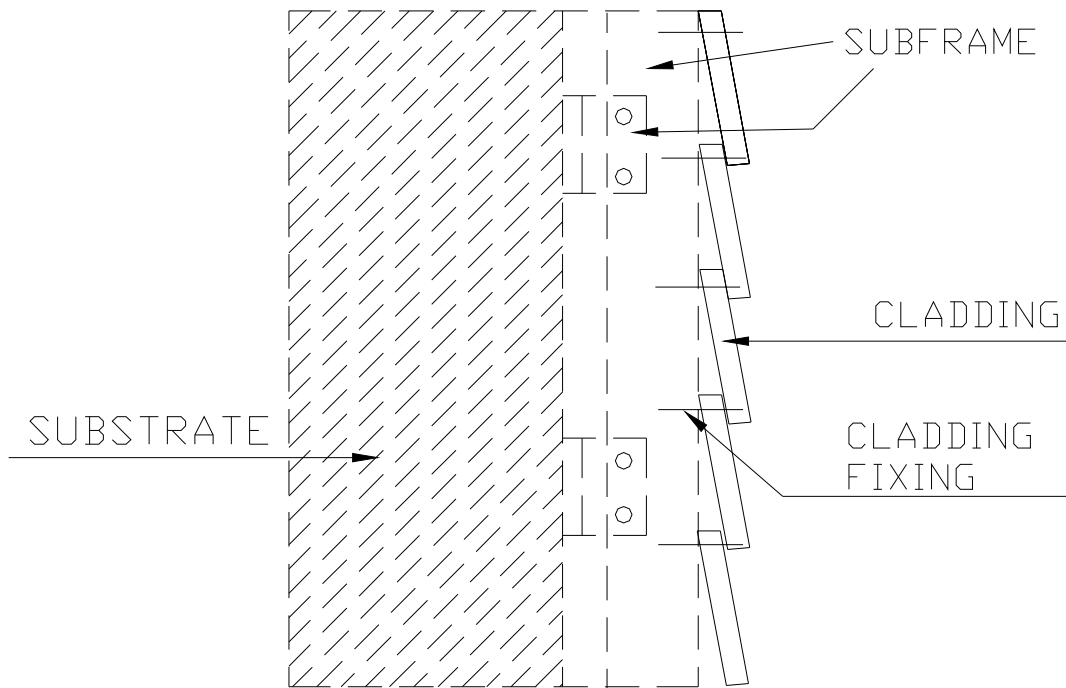

- F- Cladding kit consisting of cladding elements mechanically fastened to the subframe by at least 4 metal clips or rails

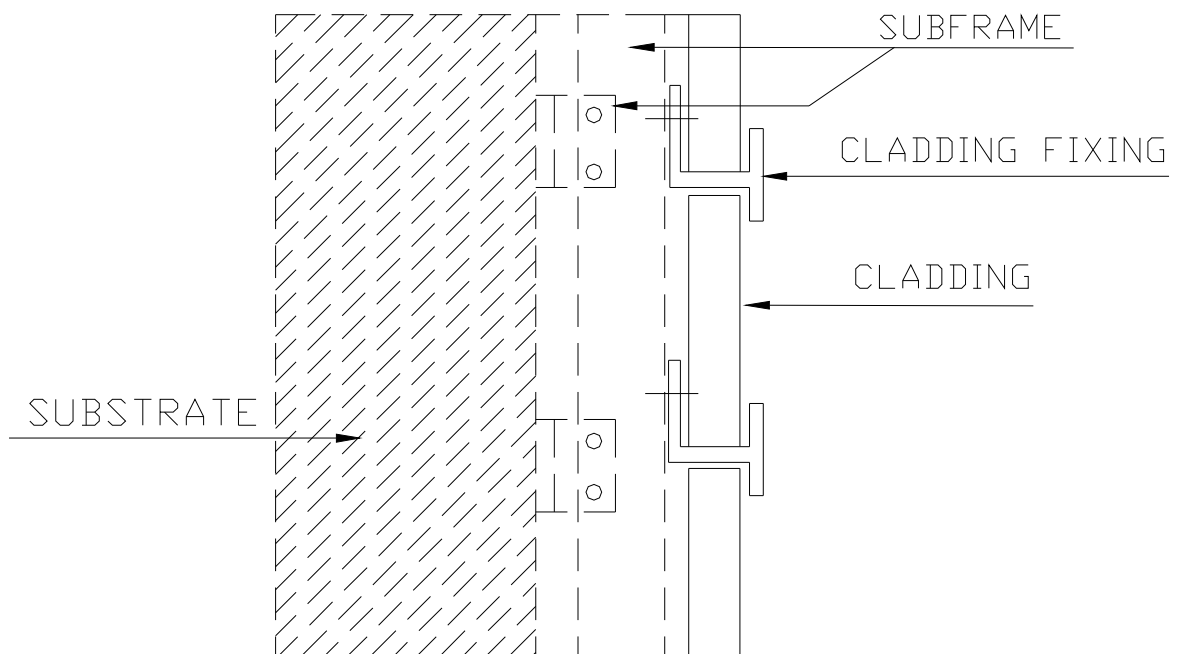

G- Cladding consisting of elements suspended on the subframe

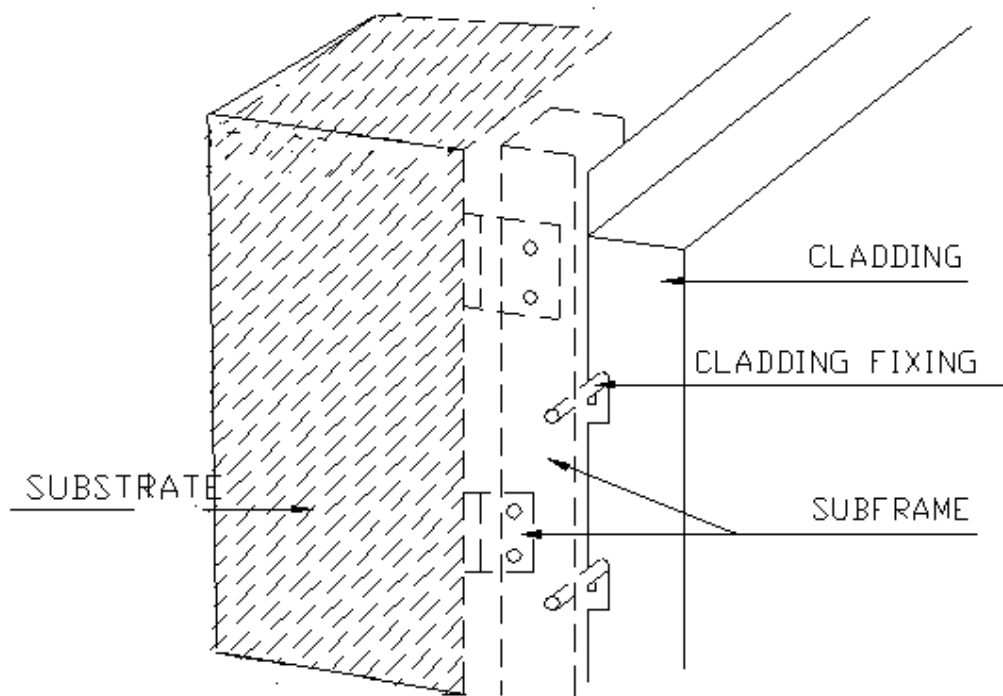

H- Tile-hung Cladding kit

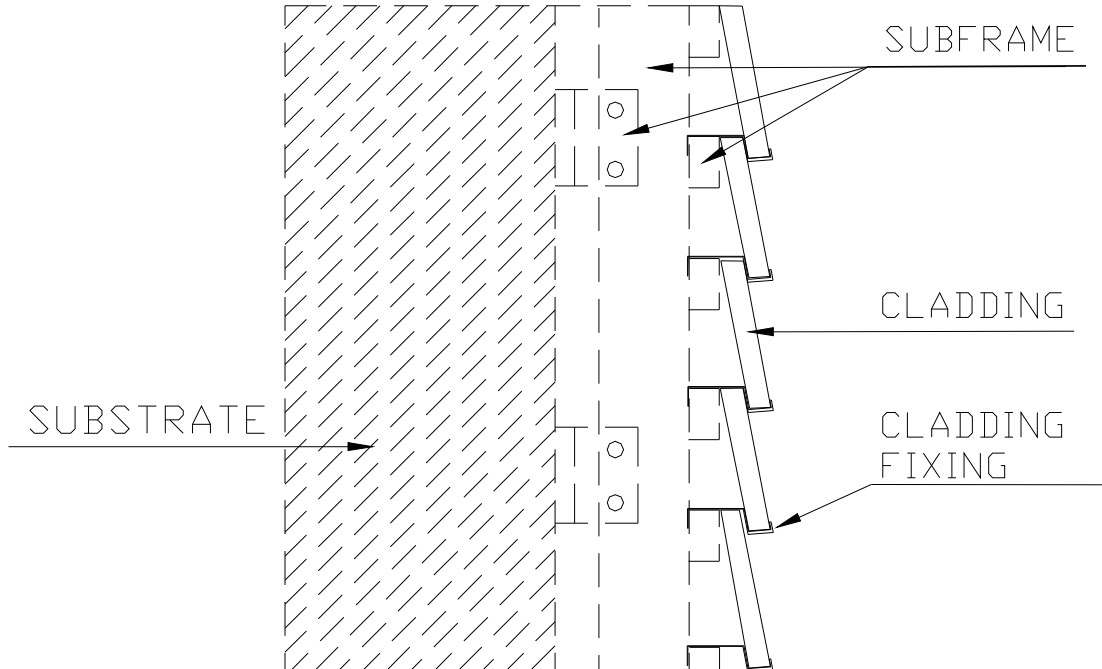

The following table gives examples of possible materials for the cladding elements and fixings

FAMILY	EXAMPLES OF CLADDING ELEMENT MATERIAL	EXAMPLES OF FIXING MATERIAL
A	Wood based, metal, stone, laminates, fibre cement or cement bonded particle boards	Corrosion protected steel, stainless steel or aluminium alloy in the form of nails, screws or rivets
B	Resin mortar, stone, ceramics, laminates or fibre-cement panel	Stainless steel anchors
C	Fibre reinforced cement, resin mortar, stone, ceramics, laminates or fibre cement panel	Aluminium alloy profiles or stainless steel pins
D	Fibre reinforced cement or plastics	Corrosion protected steel, stainless steel or aluminium alloy in the form of screws
E	Wood based, fibre cement, plastic or cement particle boards	Corrosion protected steel, stainless steel or aluminium alloy in the form of screws or nails
F	Fibre reinforced cement, fibre cement, terra cotta or ceramic tiles	Stainless steel
G	Metal cassette	Stainless steel and aluminium alloy subframe
H	Wood based panel, concrete, fibre cement, slate or terracotta tiles	Corrosion protected steel, stainless steel, copper or aluminium alloy in the form of screws, nails or brackets

## 2.2.2 Use categories

Several use categories have been adopted to correspond to the degree of exposure to Impact in use (§ 6.4.4).

## 2.3 Assumptions

The state of the art does not enable the development, within a reasonable time, of full and detailed verification methods and corresponding technical criteria/guidance for acceptance for some particular aspects or products. This ETAG contains assumptions taking account of the state of the art and makes provisions for appropriate, additional case by case approach when examining ETA-applications, within the general framework of the ETAG and under the CPD consensus procedure between EOTA members.

The guidance remains valid for other cases which do not deviate significantly. The general approach of the ETAG remains valid but the provisions then need to be used case by case in an appropriate way. This use of the ETAG is the responsibility of the ETA-body which receives the special application, and subject to consensus within EOTA. Experience in this respect is collected, after endorsement in EOTA-TB Format – Comprehension document.

### General recommendations

The content of an ETA deals with only:

- one family of cladding kit in accordance with the clause 2.2.1 (Fixing kit shall be completely described)
- one cladding material

In one ETA, there may be:

- several cladding dimensions (length, height, thickness)
- several cladding colours and surface textures
- several fixing types
- several fixing densities

## 3 TERMINOLOGY

### 3.1 Common terminology and abbreviations

(See Annex A).

### 3.2 Specific terminology

#### 3.2.1 Cladding kit

A cladding kit is a specific kit made of an external cladding and defined fixing devices which are normally, but not always, delivered together on site. The cladding is mechanically fixed to the wall using a subframe (see also EC Guidance Paper C).

Other components according to Part II can be part of the kit.

#### 3.2.2 Substrate

The term "substrate" refers to a wall, which in itself already meets the necessary airtightness and mechanical strength requirements (resistance to static and dynamic loads), as well as water tightness and a relevant water vapour resistance.

- Masonry walls



Walls constructed from units of clay, concrete, calcium silicate, autoclaved aerated concrete or stone laid using mortar and/or adhesive.

- Concrete walls

Walls made of concrete either cast in situ or prefabricated at the factory.

- Timber frame

Structural members can be studs, joists and rafters made of solid wood or wood-based materials.

- Metal frame

Structural members can be profiles made of steel or aluminium alloys materials.

### 3.2.3 Subframe

An intermediate assembly of vertical and/or horizontal, wood or metal profiles, located between the cladding elements and the substrate.

### 3.2.4 Cladding element

Sheet, plank, tile, board, panel or cassette made of durable material applied at the external face of a wall such as: wood based panels, fibre cement, concrete, stone, slate, ceramics, metal, plastics, laminates and brick slips.

### 3.2.5 Cladding fixing

Profiles, brackets, screws/anchors, nails, rivets or any special fixing devices used to secure the cladding element to the subframe.

### 3.2.6 Subframe fixing devices

Profiles brackets, rivets/screws/anchors or any special fixing devices used to fasten the subframe to the substrate and including:

- fixings within the subframe
- fixings of subframe to substrate

### 3.2.7 Ancillary materials

Any supplementary element, component or product used in the kit, e.g. to form joints (sealant, corner strips, etc...) or to achieve continuity (mastic, joint-covers, gaskets, trims, etc...).

### 3.2.8 Cavity barrier (compartmentation of air space)

Element placed in the air space to separate horizontally or vertically two compartments of air space (for fire or wind pressure purposes)

### 3.2.9 Air space

Space between the cladding and the insulation layer or substrate accordingly.

### 3.2.10 Ventilated air space

A layer of air between the substrate or insulation layer and cladding elements connected to the external environment permitting water vapour diffusion from the internal side of the wall.

External wall claddings are considered as ventilated when the following criteria are fulfilled:

- The distance between the cladding elements and the insulation layer or the substrate accordingly (ventilation air space) amounts to at least 20 mm. This air space may be reduced locally to 5 to 10 mm depending on the cladding and the subframe, provided that it is verified that it does not affect the draining and/or ventilation function,
- Ventilation openings are envisaged, as a minimum, at the building base point and at the roof edge with cross-sections of at least 50 cm<sup>2</sup> per linear metre.

### 3.2.11 Breather membrane

Membrane placed in the cladding kit which contributes to the watertightness of the wall.

# **Section two: GUIDANCE FOR THE ASSESSMENT OF THE FITNESS FOR USE**

---

## **GENERAL NOTES:**

### **a) Applicability of the ETAG**

This ETAG provides guidance on the assessment of Claddings and their intended uses. It is the manufacturer or producer who defines the cladding kits for which he is seeking an ETA and how they are to be used in the works, and consequently the scale of the assessment.

It is therefore possible that for some products, which are fairly conventional, only some of the tests and corresponding criteria are sufficient to establish fitness for use. In other cases, e.g. special or innovative cladding kits or materials the whole package of tests and assessment may be applicable and even specific tests shall have to be added.

### **b) General lay out of this section**

The assessment of the fitness of products with regard to their fitness for intended use in construction works is a process with three main steps:

- Chapter 4 clarifies the specific requirements for the works relevant to the products and uses concerned, beginning with the Essential Requirements for works (CPD art. 11.2) and then listing the corresponding relevant characteristics of products.
- Chapter 5 extends the list in chapter 4 into more precise definitions and the methods available to verify product characteristics and to indicate how the requirements and the relevant product characteristics are described. This is done by test procedures, methods of calculation and of proof, etc...
- Chapter 6 provides guidance on the assessing and judging methods to confirm fitness for the intended use of the cladding kits.
- Chapter 7, assumptions and recommendations are only relevant in so far as they concern the basis upon which the assessment of the cladding kits is made concerning their fitness for the intended use.

### **c) Levels or classes related to the essential requirements and to the product performance (see ID clause 1.2 and EC Guidance paper E)**

According to the CPD "Classes" in this ETAG refer only to mandatory levels or classes laid down, in the EC-mandate.

This ETAG indicates however the compulsory way of expressing relevant performance characteristics for the cladding kits. If, for some uses, at least one Member State has no regulations, a manufacturer always has the right to opt out of one or more of them, in which case the ETA will state "no performance determined" against that aspect, except for those properties for which, when no determination has been made the product doesn't any longer fall under the scope of the ETAG.

#### **d) Working life (durability) and serviceability**

The provisions, test and assessment methods in this guideline or referred to, have been written based upon the assumed intended working life of the cladding kits for the intended use of at least 25 years, provided that the cladding kits is subject to appropriate use and maintenance (cf. chapter 7). These provisions are based upon the current state of art and the available knowledge and experience.

An "assumed intended working life" means that it is expected that, when an assessment following the ETAG-provisions is made, and when this working life has elapsed, the real working life may be, in normal use conditions, considerably longer without major degradation affecting the essential requirements.

The indications given as to the working life of cladding kits cannot be interpreted as a guarantee given by the producer or the approval body. They shall only be regarded as a means for the specifiers to choose the appropriate criteria for cladding kits in relation to the expected, economically reasonable working life of the works (based upon ID. 5.2.2).

#### **e) Fitness for the intended use**

According to the CPD it has to be understood that, within the terms of this ETAG, products shall "have such characteristics that the works in which they are to be incorporated, assembled, applied or installed, can, if properly designed and built, satisfy the Essential Requirements" (CPD, art. 2.1). Hence, the cladding kits shall be suitable for use in construction works which (as a whole and in their separate parts) are fit for their intended use, account being taken of economy, and in order to satisfy the essential requirements. Such requirements shall, subject to normal maintenance, be satisfied for an economically reasonable working life. The requirements generally concern actions which are foreseeable. (CPD Annex I - preamble).

## **4 REQUIREMENTS**

### **Common clause:**

This chapter sets out the aspects of performance to be examined in order to satisfy the relevant Essential Requirements, by:

- Expressing in more details, for kits within the scope of the ETAG, the relevant Essential Requirements of the CPD in the Interpretative Documents and in the mandate, for works or parts of the works, taking into account the actions to be considered, as well as the expected durability and serviceability of the works,
- Applying them to kits within the scope of the ETAG (product and where appropriate its constituents, components and intended uses), and providing a list of relevant product characteristics and other applicable properties,

- When a product characteristic is specific to one of the Essential Requirements it is dealt with under that essential Requirement. If, however, the characteristic or property is relevant to more than one Essential Requirement it, is addressed under the most relevant one with cross reference to the other(s). This is especially important where a manufacturer claims “No performance determined” for a characteristic under one Essential Requirement and it is critical for the assessing and judging under another Essential Requirement. Similarly, characteristics which have a bearing on durability assessment may be dealt with under ER 1 to ER 6 with reference under 4.7. Where there is a characteristic which only relates to durability this is dealt with in 4.7.

This chapter also takes into account further requirements, (e.g. resulting from other EC Directives) and identifies aspects of serviceability including specifying characteristics needed to identify the products (cf. ETA-format § II.2).

The following Table 1 presents an overview of the Essential Requirements, the relevant paragraphs of the corresponding Interpretative Documents and the related requirements to product performance.

**Table 1 - Relationship between ID paragraph for works, Cladding kit performance and product characteristic given in the mandate**

ER	Corresponding ID paragraph for works	Corresponding ID paragraph for kit performance	Mandate product characteristic	ETAG paragraph on kit performance
1	-	-	-	-
2	4.2.3.4 Limitation of spread of fire and smoke beyond the room of origin: Walls	4.3.1.1 Products subject to reaction to fire requirements: Façades / external walls 4.2.3.4.2 Façades/external walls Fire spread in cavities inside the façades, along the outside surface of the façade and from one fire compartments	Reaction to fire  Fire resistance against: - Fire from the inside - Fire from the outside	4.2 ER2:Safety in case of fire  4.2 ER2:Safety in case of fire
3	3.3.1.2 Indoor environment	3.3.1.2.2 Dampness control	Watertightness of joints Water permeability Water vapour permeability Drainability	4.3.1 ER3:Indoor environment dampness
	3.3.5 outdoor environment	3.3.5.3 : Release of pollutants to outdoor air, soil and water	Content and/or release of dangerous substances	4.3.2 Outdoor environment
4	3.3.2 : Direct impacts Impacts of falling objects, forming part of the works, upon users	3.3.2.2 : Performance of the works	Resistance to wind load Mechanical resistance of fixing Resistance to horizontal point loads Impact resistance Shatter properties	4.4 ER4:Safety in use

			Resistance to seismic actions Hygrothermal behaviour	
5	4.2 Protection against airborne noise from outside of the works	4.3.2 Acoustic properties and their expression acoustic performance of the kit	Airborne sound insulation	4.5 ER5:Protection against noise
6	4.2.3 Expression of the energy requirements and their relation to the products characteristics	4.3.2 Characteristics of products which may be relevant to the essential requirement	Thermal resistance	4.6 ER6:Energy economy and heat retention
Aspects of durability and serviceability	Other durability aspects		Fatigue Dimensional stability Freeze-thaw chemicals and biological resistance corrosion UV radiation	4.7 Aspect of durability and serviceability

#### 4.1 ER1: MECHANICAL RESISTANCE AND STABILITY

Requirements with respect to the mechanical resistance and stability of non load bearing parts of the works are not included in this Essential Requirement but are treated under the Essential Requirement Safety in use (see Clause 4.4).

#### 4.2 ER2: SAFETY IN CASE OF FIRE

##### 4.2.1 Reaction to fire

The reaction to fire performance of cladding kits shall be in accordance with laws, regulations and administrative provisions applicable to the kit in its intended use application. This performance shall be expressed in the form of a classification specified in accordance with the relevant EC Decision 96/603/EEC as amended and/or EN 13501-1 and/or an appropriate CWFT decision.

##### 4.2.2 Fire resistance

The fire resistance requirement is applicable to the wall itself (made of masonry, concrete, timber or metal frame) and not on the cladding kits. The cladding kit alone does not meet any fire resistance requirements.

The evaluation of "Fire propagation to upper levels" is not part of the European classification and thus, cannot be evaluated, i.e. to be omitted.

#### 4.3 ER3: HYGIENE, HEALTH AND ENVIRONMENT

##### 4.3.1 Indoor environment, dampness

As far as dampness is concerned for external walls, two requirements have to be considered, for which Cladding kits have a favourable effect:

- Moisture proofing from outside damp.

External walls shall resist the penetration of rain and snow to the inside of the building; they shall not be damaged by rain and snow and shall not carry moisture to any part where it could cause damage.

- Avoiding condensation on internal surfaces of the wall and interstitial condensation.

Surface condensation is usually reduced by the application of cladding kits.

Under normal conditions of use, harmful interstitial condensation does not occur in the kit. Where there is a high incidence of water vapour internally, appropriate precautions shall be taken to prevent the kit from becoming damp, for example by suitable design of the products and choice of materials.

This means that for ER3 the protection against driving rain, water permeability (does not apply to kits with a ventilated air space), water vapour permeability (does not apply to kits with a ventilated air space) and drainability characteristics have to be assessed for the kit and/or each of its components.

#### 4.3.2 Outdoor environment

The kit shall be such that, when installed according to the appropriate provisions of the Member States, it allows for the satisfaction of the ER3 of the CPD as expressed by the national provisions of the Member States and in particular does not contaminate the outdoor environment (air, soil or water).

- Used wood

Used wood are used products made from solid wood, wood based products or made from laminates, predominantly containing wood. In the case of wood-based panels as cladding: In some Member States there are special regulations for the use of used woods, which have to be met. Therefore the information if used wood is used for the production of wood-based panels has to be given.

- Biocides

Only such biocides may be applied which are approved according to Commission Directive 98/8/EC of the European Parliament and of the Council. As long as the Annexes of the directive are not implemented, a declaration of the biocides, the amount and the state of the treatment has to be given. Alternatively for wood preservatives a marking "PT"(treated with wood preservatives) according EN 13986 is possible.

- Flame retardant/fire retardant

A declaration of the flame/fire retardant, the amount and the state of the treatment has to be given. A declaration, that no polybromated diphenylether are used, has to be given.

- Formaldehyde

If formaldehyde-containing resins are used for the production of wood-based panels, the release or the content of formaldehyde shall be determined.

Note: In some Member States formaldehyde emitting products above class E1 (< 0,124 mg/m<sup>3</sup> in application of the measurement method foreseen in the relevant standard) are prohibited.

- Pentachlorophenol

If relevant, the content of pentachlorophenol shall be determined and declared.

Note: In some Member States, kits/components which contain PCP are totally prohibited or have a specific limit value.

- Man made mineral fibres

Man made mineral fibres, which are declared as cancerogenic of the EU category II shall not be used.

Asbestos is forbidden by European directive 76/769, and shall therefore not be used.

- Ceramic fibres  
Although it is recommended that ceramic fibres should not be used, their presence does not prevent a kit from complying with the provisions of this ETAG, as long as this is consistent with regulatory requirements in the Member State of use.
- Cadmium  
The content of cadmium and cadmium compounds contained in plastics, paints, lacquers, varnishes, zinc or zinc coatings and used as a coating shall meet the respective regulations.

#### 4.4 ER4: SAFETY IN USE

Even though Cladding is a kit without a structural intended use, mechanical resistance and stability is still required.

The installed kits shall be stable to the combined stresses generated by normal loads such as intrinsic weight, temperature, humidity and shrinkage, as well as movements of the substrate, direct impacts and wind forces (pressure and suction).

*This means that for ER 4, the following products characteristics have to be assessed for the kit and/or its components:*

##### Effect of intrinsic weight

The kit shall support itself without harmful deformation.

##### Impact resistance

The kit shall be designed so that it retains its properties under the effect of impacts caused by normal traffic and normal use. Its performance shall be such that the effect of normal accidental or deliberately caused unexceptional impact does not cause damage which results in injury to persons e.g. dangerous cutting edges or the falling of objects forming part of the works upon users. Damage caused by impacts shall not result in the kit failing to continue to satisfy any of the other relevant Essential Requirements, e.g. damage resulting in water penetration compromising ER 3.

##### Shatter properties

Cladding products shall not, in the event of breakage, present sharp or cutting edges. Their surface shall not cause bodily injury, either for the occupants or for people nearby.

##### Horizontal point loads

Unless the manufacturer, in his installation and maintenance information, specifically excludes it, it shall be possible to lean standard maintenance equipment against the kit, without causing damage which results in injury to persons e.g. dangerous cutting edges or the falling of objects forming part of the works upon users or which results in the kit failing to continue to satisfy any of the other relevant Essential Requirements, e.g. damage resulting in water penetration compromising ER 3.

##### Effect of the wind action

The kit shall exhibit appropriate mechanical resistance to the forces of pressure, suction and vibration, due to wind.

##### Effect of seismic actions

When applicable, relevant Eurocodes, European and/or national regulations shall be taken into account.

##### Behaviour under hygrothermal variations

The external cladding shall withstand movements due to humidity and temperature variations except at structural joints where special precautions have to be taken.



#### 4.5 ER5: PROTECTION AGAINST NOISE

Not relevant to Part I.

#### 4.6 ER6: ENERGY ECONOMY AND HEAT RETENTION

Not relevant to Part I.

#### 4.7 ASPECTS OF DURABILITY AND SERVICEABILITY

All of the ER's mentioned above shall be fulfilled for the life of the kit under the actions to which it is subjected.

##### Kit durability

The cladding kits shall be stable to temperature variation, humidity, shrinkage and/or swelling, freeze-thaw cycles, chemical and biological attacks, corrosion and UV radiation.

##### Performance on exposure to movements of the substrate

Normal movements of the substrate shall not give rise to any crack formation in the kit. The cladding kits shall withstand movements due to the temperature and stress variations except at structural joints where special precautions have to be taken.

Neither high nor low temperatures shall exercise a destructive or irreversibly deforming effect.

Low air temperatures of the order of - 20°C and high air temperatures of + 50°C are generally regarded as the extremes in temperature change. In northern European countries however, the temperatures of the air can decrease to - 40°C.

Solar radiation increases the surface temperatures of the cladding kits when exposed. The increase depends on the radiation flow and the energy absorption of the surface (colour). It is generally considered that the maximum surface temperature is + 80°C (e.g. for opaque cladding elements).

A change (of the order of 50°C) in the surface temperature shall not cause any damage, e.g. a sudden change due to prolonged exposure to solar radiation followed by intensive rain, or the change of temperature between sun and shade.

In addition, steps shall be taken to prevent crack formation both at the expansion joints of the works and where elements of the wall are of different materials, e.g. connections to windows.

##### Durability of components

All components shall retain their properties during the overall service life of the kit under normal conditions of use and maintenance such that the kit conformity is maintained. This requires the following:

- All components shall display chemical-physical stability.
- All materials shall be either naturally resistant to, or be treated or protected against attack by corrosion, fungus or UV radiation.
- All materials shall be compatible with each other.
- Components possibly susceptible to moisture penetration shall be subject to axial tension tests after water immersion.

## 5 METHODS OF VERIFICATION

This chapter refers to the verification methods used to determine the various aspects of performance of the products in relation to the requirements for the works (calculations, tests, engineering knowledge, site experience, etc...). The possibility exists to use existing data in accordance with the EOTA Guidance Document 004 on the "Provision of data for assessment leading to ETA".

Depending on the design of the kit, the approval body shall determine the assessment program (tests, calculation...) and in particular the relevance of the tests listed here after.

In order to assess and judge Claddings it is often necessary to adopt verification methods which require the testing of two or more components in a small scale assembly. As such, they are neither kits nor components. By taking this approach, it is possible to either avoid a large number of full scale tests or at least limit the number required, by enabling the selection of the appropriate combination of components to provide an assessment of the complete **kit**.

Therefore, the structure of this chapter is that these tests relate to the kit rather than to the individual components.

In any test report, the tested products shall be described with information about material, geometry, subframe and fixing method.

The relevant Essential Requirements, the relevant verification methods related to the essential requirements and the related product characteristics to be assessed are indicated in the following Table 2.

**Table 2 – Verification of performance**

ER	ETAG Paragraph on product performance	Product characteristic	ETAG paragraph on verification method	
			Kit	Component
1	-	-	-	-
2	4.2 Safety in case of fire	Reaction to fire  Fire resistance	5.2.1 and 5.2.2 Reaction to fire  5.2.3 Fire resistance	
3	4.3.1 Indoor environment, dampness	Watertightness of joints  Water permeability  Water vapour permeability Drainability	5.3.1 Watertightness of joints (protection against driving rain)  5.3.2 Water permeability of cladding element (resistance to water diffusion)  5.3.4 Drainability	5.3.3 Water vapour permeability
	4.3.2 outdoor environment	Content and/or release of dangerous substances	5.3.5 Content and/or release dangerous substances	5.3.5 Content and/or release of dangerous substances
4	4.4 Safety in use	Wind load resistance  Mechanical resistance of fixing  Resistance to horizontal point loads  Resistance to impact - Shatter properties Resistance to seismic actions  Hygrothermal behaviour	5.4.1.1 <i>Wind suction test</i>  5.4.1.2 <i>Wind pressure test</i>  5.4.2 Mechanical test  5.4.3 Resistance to horizontal point loads  5.4.4 Impact resistance  5.4.5 Resistance to seismic actions  5.4.6 Hygrothermal behaviour	
5	4.5 Protection against noise	Airborne sound insulation	5.5 ER5 Protection against noise	-
6	4.6 Energy economy and heat retention	Thermal resistance	5.6 ER6 Energy economy and heat retention	-

Aspects of durability and serviceability	4.7 Aspects of durability and serviceability	Fatigue  Dimensional stability  Freeze-thaw  chemicals and biological resistance  Corrosion  UV radiation		5.7.1 Pulsating load 5.7.2 Dimensional stability of external cladding 5.7.3 Immersion in water 5.7.4 Freeze-thaw 5.7.5 Chemical and biological resistance 5.7.6 Corrosion 5.7.7 UV radiation
--	--	---	--	--

## 5.1 ER1: Mechanical resistance and stability

This requirement is not relevant to cladding kits (see ER4 Safety in Use).

## 5.2 ER2: Safety in case of fire

### 5.2.1 Reaction to fire in intended used

Except where the reaction to fire performance of the kit can be known, the cladding kit and its components shall be tested, using the tests methods relevant for the corresponding reaction to fire class, in order to be classified according to EN 13501-1: 2007.

Where all components of the kit are class A1 without testing according to Decision 96/603/EEC as amended, the whole kit may be classified Class A1 without testing. Where one or more of the components is classified according to a CWFT Decision, the whole kit may be classified to the lowest class of any component.

The potential contribution of a product to a fire does not only depend on its intrinsic properties and the thermal attack, but also to a large extent on its end-use situation when incorporated in the works. Tests shall be conducted therefore to simulate its end-use situation.

The reaction to fire classification and relevant testing shall be given for the entire kit, e.g. if the cladding is intended used to be applied with thermal insulation behind, it shall be tested with this insulation.

EN 13823 gives only a general description of the arrangement of the test specimen. Unless European Standard exists (e.g. EN 438-7), Annex E includes precise, specific information about the SBI-Testing for cladding kits.

For the time being, performing assessments according to the reaction to fire tests are judged sufficient in some countries for the determination of the behaviour in fire of the cladding kits; in Member States where regulatory requirements demand full-scale façade testing, such testing shall be performed according to national provisions (no European method currently existing). Such testing does not form part of the ETA assessment.

## 5.2.2 Reaction to fire on back side

Asymmetrically composed cladding elements may have to be tested and classified according to the provisions of EN 13501-1:2007. When tested the SBI test (EN 13823), the test shall involve a free-hanging arrangement with the flame impingement to the rear side in accordance with EN 13823 (test arrangement without open joints between the cladding elements and without insulation layer on A1 or A2 substrate, so that the distance between the substrate and the cladding elements amounts to at least 80 mm).

## 5.2.3 Fire resistance

Not relevant.

## 5.3 ER3 : Hygiene, health and the environment

### 5.3.1 Watertightness of joints (protection against driving rain)

Cladding kits contribute to the watertightness of the wall. The degree of watertightness of a cladding kit is generally assessed by appraisal of design, taking account of the characteristics of the materials used and the geometry of external cladding element and joints.

Open joints are not watertight.

If joints are not watertight, the insulation layer shall be made of EPS to EN13163, XPS to EN 13164, PUR to EN 13165, phenolic foam to EN 13166 or mineral wool to EN 13162 (WS or WL(P), depending on the national regulations).

If watertightness of closed joints is needed, an artificial rain test shall be carried out on the cladding kit in accordance with EN 12865 Procedure A (600 Pa maximum). A translucent panel (PMMA thickness 8 mm) with 3 mm diameter holes (0,01 % holes) is placed behind the cladding (Figure 2 and Figure 3).

For example, if the size of sample is 2 400 x 1 200 mm, the display of holes can be made according to Figure 1.

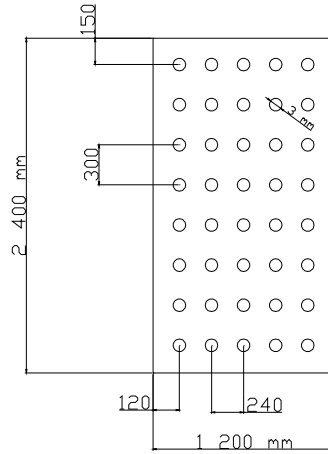

**Figure 1 – Example of distances between holes**

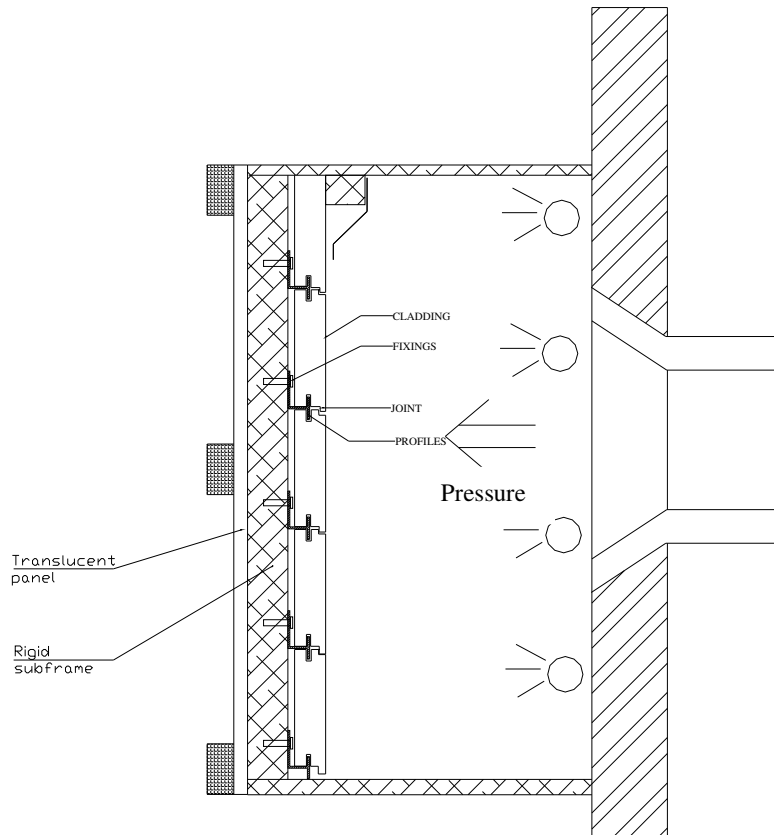

**Figure 2 - Example of test device – vertical section**

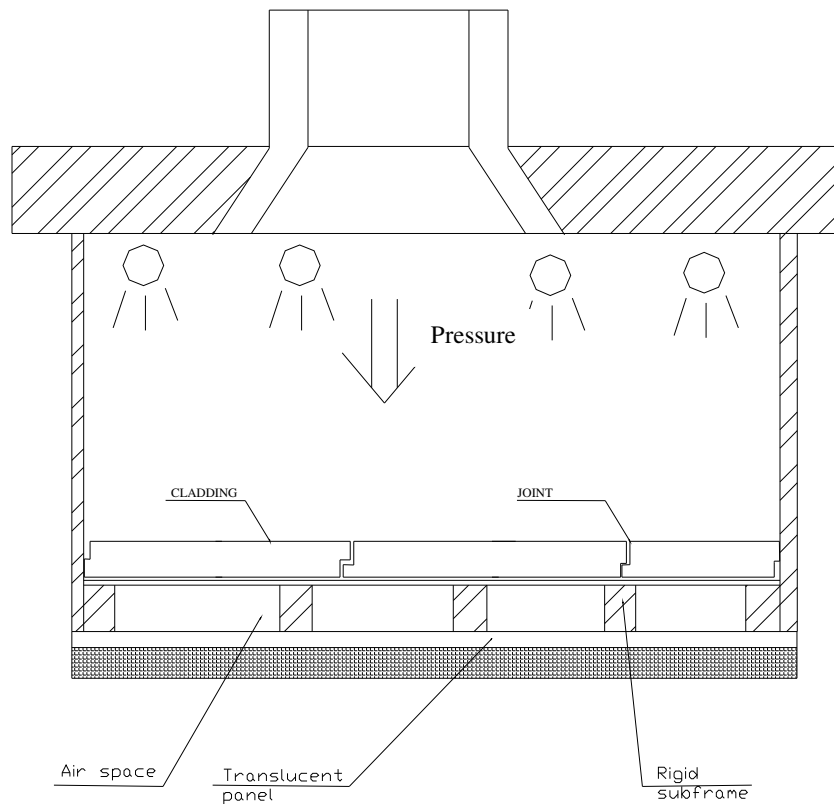

**Figure 3 - Example of test device – horizontal section**

### 5.3.2 Water permeability of cladding element (resistance to water diffusion)

The test is not relevant due to the fact that only kits designed with ventilated air space are considered in this part.

### 5.3.3 Water vapour permeability

The test is not relevant due to the fact that only kits designed with ventilated air space are considered in this part.

### 5.3.4 Drainability

The drainability of a cladding kit is generally assessed by appraisal of design taking into account of the characteristics of materials used and geometry of external cladding and joints.

The cladding kit shall be designed and installed so that water which penetrates in the air space or condensation water shall be drained out of the installed kit without accumulation or moisture damage or leakage into the substrate or the wall cladding kit.

## 5.3.5 Content and/or release of dangerous substances

### 5.3.5.1 Content and/or release of dangerous substances in the product

The applicant shall submit a written declaration stating whether or not the product/kit contains dangerous substances according to European and national regulations, when and where relevant in the Member States of destination, and shall list these substances.

#### Used wood

In case of wood-based panels as cladding element, the use of used wood for the production of cladding elements has to be declared by the applicant.

#### Biocides

The use of biocide(s) has to be declared by the applicant stating the trade name(s) of the biocide(s), the chemical name(s) of the active component(s), the amount(s) and the technical procedure of application. Alternatively for wood preservatives a marking "PT" (treated with wood preservatives) according to EN 13986 is possible.

#### Flame retardant/fire retardant

The use of flame/fire retardant(s) has to be declared by the applicant stating the trade name(s) of the flame/fire retardant(s), the chemical name(s) of the active component(s), the amount(s) and the technical procedure of application. A declaration, that no polybromated diphenylether is used, has to be given.

Note: CEN TC 351 is harmonizing test methods for polybrominated and therein contained polyhalogenated dibenzodioxines and polyhalogenated dibenzofuranes. Therefore the verification is provisionally, because harmonized European provisions are missing. Coming European provisions could request other verification methods.

#### Formaldehyde

If formaldehyde containing resins are used for the production of wood based panels, the assessment of the release or the content of formaldehyde shall be performed according to EN 13986; for laminates it shall be performed according to EN 438-7.

#### Pentachlorophenol

If relevant, the content of pentachlorophenol shall be determined according to CEN/TR 14823 or shall be performed in accordance with a test procedure that reflects the state of the art.

Note: CEN TC 351 is harmonizing test methods for PCP. Therefore the verification is provisionally, because harmonized European provisions are missing. Coming European provisions could request other verification methods.

#### Man made mineral fibres

Man made mineral fibres shall only be used if they fulfil one of the conditions of the method I or method II.

##### Method I

Proof that a suitable intraperitoneal test did not express signs of excessive carcinogenicity. The half life of intratracheal instillation of a 2 mg fibre - suspension for fibres longer than 5



µm, a diameter less than 3 µm and a relation of length to diameter greater than 3:1 (WHO-Fasern) does not exceed 40 days.

The "Kanzerogenitätsindex KI", resulting from the difference between the sum of the mass contents (in %) of the oxides of sodium, potassium, boron, calcium, Magnesium, barium and the double mass content (in %) of alumina results, shall be at least 40.

#### Method II

The product has to meet the requirements given in comment Q and R of the Directive 97/69/EC.

Note 1: For some Member States, method I is mandatory.

Note 2: CEN TC 351 is harmonizing test methods for man-made vitreous (silicate) fibres with random orientation with alkaline oxide and alkali earth oxide content greater than 18% by weight.. Therefore the verification is provisionally, because harmonized European provisions are missing. Coming European provisions could request other verification methods.

#### Ceramic fibres

If appropriate, the use of ceramic fibres shall be declared by the applicant.

Note 1: Ceramic fibres should be substituted.

Note 2: If the applicant can show sufficiently, that there are no alternative products on the market available to achieve the technical behaviour of insulation material, the approval body can decide to approve the product/kit anyway, subject to any regulatory requirements on the use of ceramic fibres being met.

#### Cadmium

The content of cadmium contained in plastics, paints, lacquers, varnishes, zinc or zinc coatings shall be determined. If cadmium or a cadmium compound is used as a coating, this shall be declared by the applicant.

Note: CEN TC 351 is harmonizing test methods for cadmium or cadmium compounds. Therefore the verification is provisionally, because harmonized European provisions are missing. Coming European provisions could request other verification methods.

#### 5.3.5.2 Compliance with the applicable regulations

If the product/kit contains dangerous substances as declared above, the ETA will provide the method(s) which has been used for demonstrating compliance with the applicable regulations in the Member States of destination, according to the EU data-base <http://ec.europa.eu/enterprise/construction/cpd-ds/index.cfm> (method(s) of content or release, as appropriate).

#### 5.3.5.3 Application of the precautionary principle

An EOTA member has the possibility to provide to the other members, through the Secretary General, warning about substances which, according to Health authorities of its country, are

considered to be dangerous under sound scientific evidence, but are not yet regulated. Complete references about this evidence will be provided.

This information once agreed upon, will be kept in an EOTA data base, and will be transferred to the Commission services.

The information contained in this EOTA data base will also be communicated to any ETA applicant.

On the basis of this information, a protocol of assessment of the product, regarding this substance, could be established on request of a manufacturer with the participation of the Approval Body which raised the issue.

## 5.4 ER4 : Safety in use

A control of the mechanical properties of the products used for the tests has to be performed.

If the test results according to 5.4.2 are better than the mechanical properties to be declared in the ETA, an appropriate reduction of the test results according to 5.4.1, proportional to the characteristic value of thickness and the characteristic value of modulus of elasticity or rupture strength is necessary (e.g. for thickness : ratio of cubic value).

### 5.4.1 Wind load resistance

Both the tolerance due to manufacturing and/or installation and deformations due to temperature and humidity variations have to be taken into account and the most critical case shall be tested. The most critical case shall be explained.

One test specimen for each chosen geometry is performed. If the test result obtained does not confirm the results obtained by mechanical tests in accordance with §5.4.2, at least two other test specimen have to be tested.

#### 5.4.1.1 Wind suction test

The principle is to reproduce the effects of suction on the cladding kit.

The number of tests depends on the combination of parameters presented for the kit approval.

As a minimum, the weakest design mechanically is tested.

#### **Preparation of the test specimen**

The test specimen shall be mounted in the test rig in accordance with the manufacturer's instructions.

The test specimen comprises:

- a non airtight substrate (test rig) such as wood or steel rigid frame or masonry or concrete wall with one hole per square metre, with a diameter at least 15 mm.
- the cladding secured with the specified fixing devices for the kit (adapted to the frame)
- The dimensions of the test specimen depend on the size of external cladding element and the specified fixing devices :

- \* for cladding elements which are mechanically fixed independent of each other (i.e. Case A, B, F or G), a minimum surface cladding of 1,5 m<sup>2</sup> shall be tested.
- \* If they depend on each other vertically and horizontally (i.e. Case D or H), at least 3 x 3 elements shall be tested.
- \* If they depend on each other vertically or horizontally (i.e. Case C or E), at least 4 elements shall be tested.

The air permeability of the test specimen can be reduced provided no interference with mechanical resistance of the test specimen occurs.

### **Test equipment**

The test equipment consists of a pressure or suction chamber against which is placed the test rig. The depth of chamber shall be sufficient for a constant pressure or suction to be exerted on the test specimen (applied to the front surface of external cladding element) irrespective of its possible deformation. The chamber is mounted on a rigid frame. The cladding serves as the seal between the chamber and the environment. The connection between the cladding element and the chamber shall be sufficient to allow a realistic deformation of the test kit under the influence of simulated wind suction.

### **Test procedure**

The uniformly distributed loads are exerted on the front face of external cladding elements.

The test is performed in successive steps (two steps of 300 Pa, one step to 500 Pa and then one step of 1000 Pa, then steps of 200 Pa thereafter, with a return to between zero and 300 Pa after each step), until significant irreversible deformation (deformation which affect the fitness for use) or failure occurs (see figure 5).

At each level, the load is maintained constant for at least 10 s, after stabilization of cladding deformations.

The test is then continued until failure occurs.

The deflection shall be measured, if appropriate, at the cladding element and on the fixing as a function of reduced pressure and reported in tabular or graphic form.

With the differential pressure reduced to zero, the permanent deflection shall be noted after 1 minute recovery. The reduced pressure at which defect or damage occurred shall be noted.

The pins fixing the cladding to the test slab shall not constitute weak points and shall therefore be chosen accordingly.

### **Observations during the test**

Failure is defined by any one of the following events:

1. Any cladding elements breaks,
2. Any cladding element presents a significant permanent deflection,
3. The failure of fixings,
4. The failure or detachment of the frame.

### **Test results**

The test result is°:

- the load Q for which the test specimen fails (Take the last pressure)
- the type of failure
- the value of deflection as a function of the load given in graphic form

The test results are only valid for those fixing patterns tested.

**Test specimen description**

It is necessary to describe the test specimen by giving details about:

- External cladding elements: geometry and dimensions
- Fixing system
- Fixing density
- Subframe (material properties, section, distance between the supports).

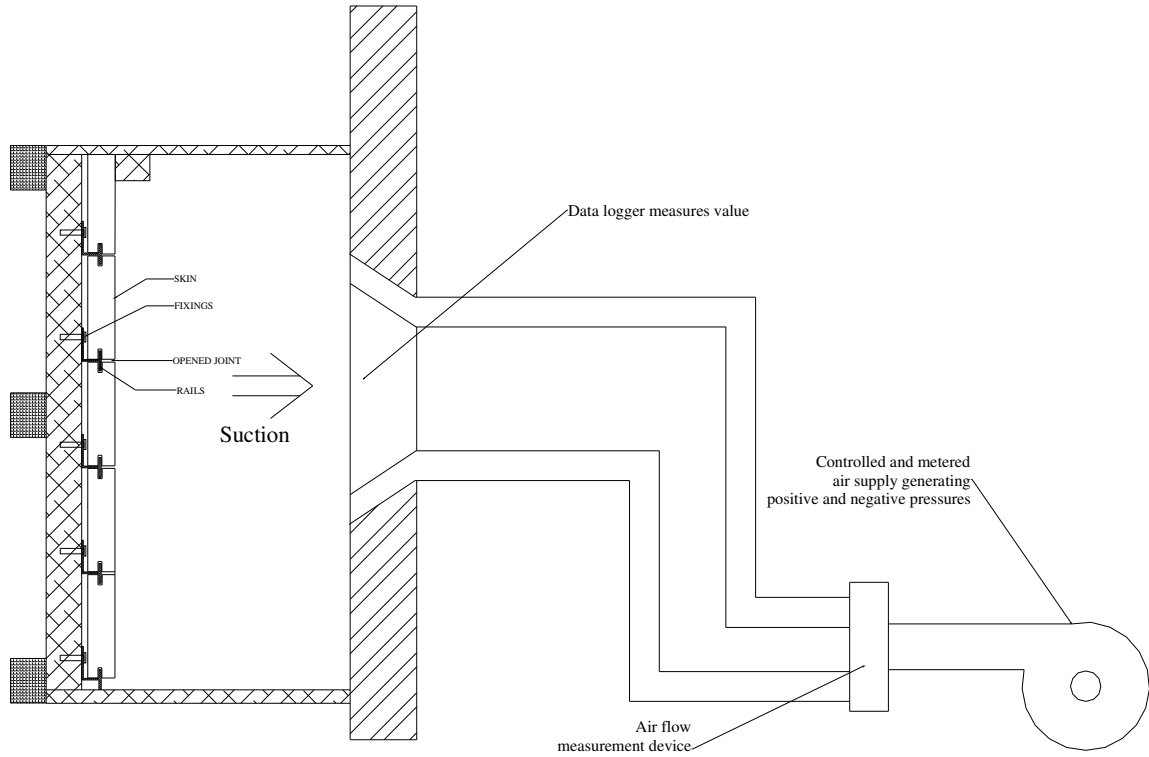

Figure 4 - Example of wind pressure and suction apparatus

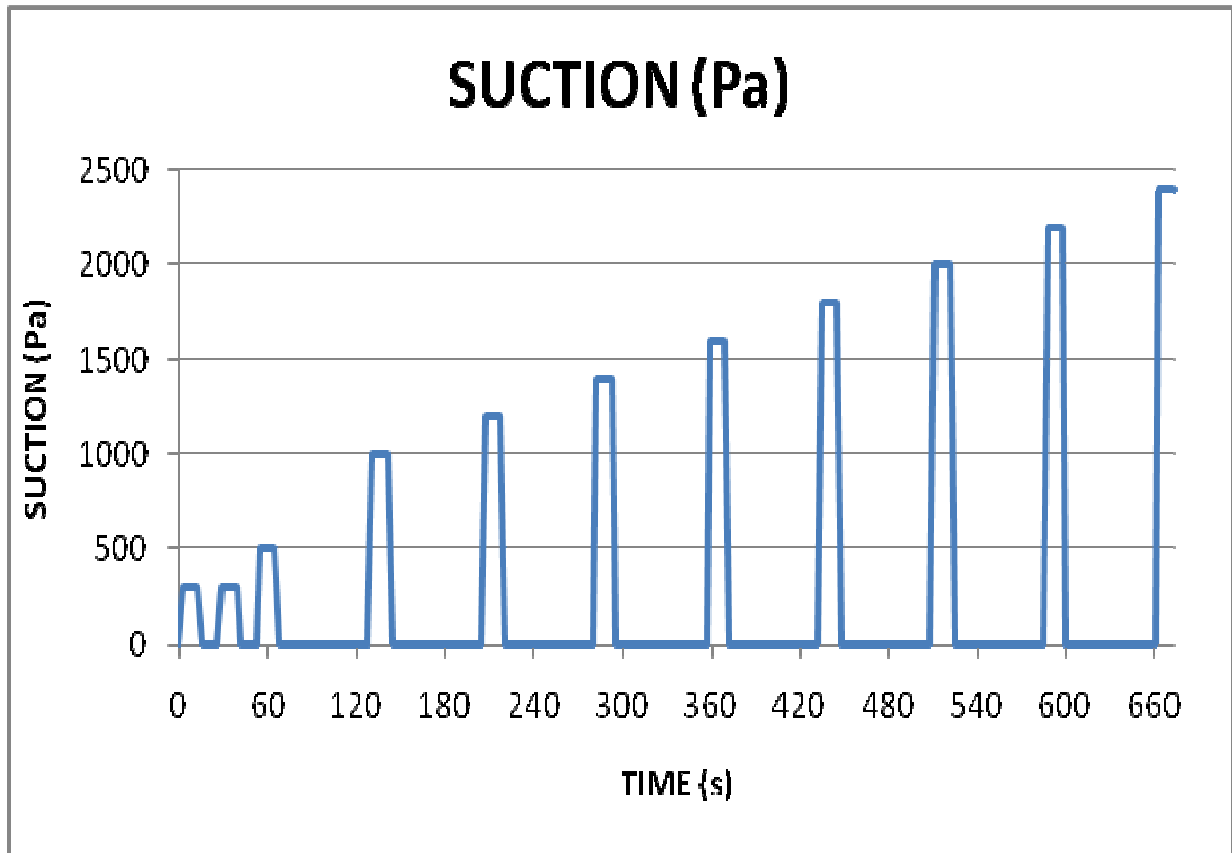

Figure 5 - Example of wind load design

### **Alternative test method**

The alternative test may be used for all product families, provided that the geometric shape allows the foil bags to be placed in the air space and be blown out so that a uniformly distributed pressure load at the rear face of the cladding is possible (for families E, G and H, this method is not recommended).

### **Preparation of the test specimen**

The test specimen shall be mounted such as defined in the last test.

### **Test equipment**

The test rig consists of a rigid frame (steel construction) made of vertical longitudinal girder and horizontal profiles (anchor channel) and rigid boards or a massive wall such as masonry or concrete.

The subframe of the cladding kit has to be fixed on the rig and the cladding elements have to be fixed on the subframe according to the indications given by the ETA applicant.

The vertical profiles of the rig can be movable (sliding) so that they can be placed in the axis of the fixings of the cladding.

Foil bags which are placed in the air space at the rear side of the cladding are blown out and they exert a uniformly distributed pressure load on the rear face of the cladding which corresponds to the wind suction load.

### **Test procedure**

Two pressure pulses between zero and 300 Pa shall be applied.

The test is performed in successive steps of 500 Pa up to 1000 Pa and 200 Pa after 1000 Pa, with a return to zero at each level, until significant irreversible deformation occurs (see Figure 5). At each level, the load is maintained constant for ca. 10 seconds after stabilization of the cladding deformations and the displacements are measured.

The test is then continued until failure occurs.

The deflection shall be measured at the cladding element and on the fixing as a function of the load and reported in tabular or graphic form.

The failure load for which there is a defect or damage in the kit shall be noted.

When the surface on which the load is applied is different from the whole surface of the tested cladding for construction reasons, the failure load reached during the test has to be corrected and reduced by calculation considering the surface on which the load is applied in relation to the whole surface of the tested cladding. The failure load given in the test report shall always refer to the whole surface.

The fixings of the subframe to the test rig shall not constitute weak points and shall therefore be chosen accordingly.

### **Observations during the test**

Failure is defined by any one of the following events:

- Any cladding elements breaks,
- Any cladding element presents a permanent deflection.
- The failure of fixings.
- The failure or detachment of the frame.

### **Test results**

The test result is °:

- the load Q for which the test specimen fails (Take the last pressure)
- the type of failure
- the value of deflection as a function of the load

The test results are only valid for those fixing patterns tested.

### **Test specimen description**

It is necessary to describe the test specimen by giving details about:

- External cladding element: geometry and dimensions
- Fixing system
- Fixing density
- Subframe (material properties, section, distance between the supports).

#### 5.4.1.2 Wind pressure test

In cases where for the resistance to wind pressure may be lower than the resistance to wind suction, supplementary tests with a wind pressure load have to be performed. Otherwise the wind pressure is equal to the wind suction resistance.

The test procedure is similar to § 5.4.1.1, only the wind action is reversed.

#### 5.4.2 Mechanical test

For all cladding products, the bending strength, modulus of elasticity and rupture of the product, determined according to Annex C is required.

The material and geometric properties of the fixings are to be declared according to either relevant EN standard or ETAG. Otherwise the pull-out resistance has to be determined by testing.

The fasteners shall be installed in accordance with the manufacturer's installation instructions.

Both the tolerance due to manufacturing and/or installation and dimensional variations due to temperature and humidity variations have to be taken into account and the most critical case shall be tested.

Depending on the family and the materials used and on the design of the kit, the mechanical resistance of the fixings has to be tested in ambient conditions (reference tests) and also, if relevant, after the effects due to sustained loading.

The tests shall be carried out on the envisaged cladding material to be fixed.

The material used for the tests shall be specified in detail.

#### 5.4.2.1 Family A

##### 5.4.2.1.1 Pull-through resistance of cladding element

Testing of pull-through resistance of the panel is carried out in accordance with the following test procedure.

The test is performed in ambient conditions, until failure by pulling through.

Samples with a fixing driven through the centre, corner and middle of each sample are applied as show in Figure 6 and Figure 7.

The size of samples shall be given in function of supporting ring diameter.

The test series shall be evaluated separately on 3 rings between 50 and 350 mm. For fibre-cement and laminates panels, 180, 270 and 350 mm are recommended.

An axial tension load is exerted on the fixing. *The* speed rate shall be adjusted to 5 mm/min. The force can be applied either by pushing on the head of the anchor or pulling the end of the anchor.

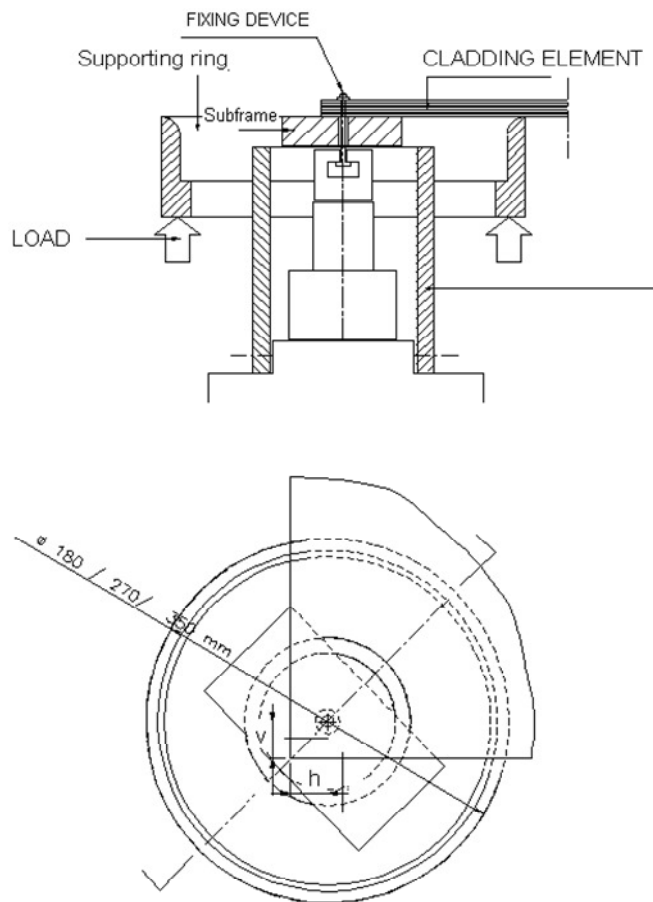

**Figure 6 - Example of test on fixing in corner**



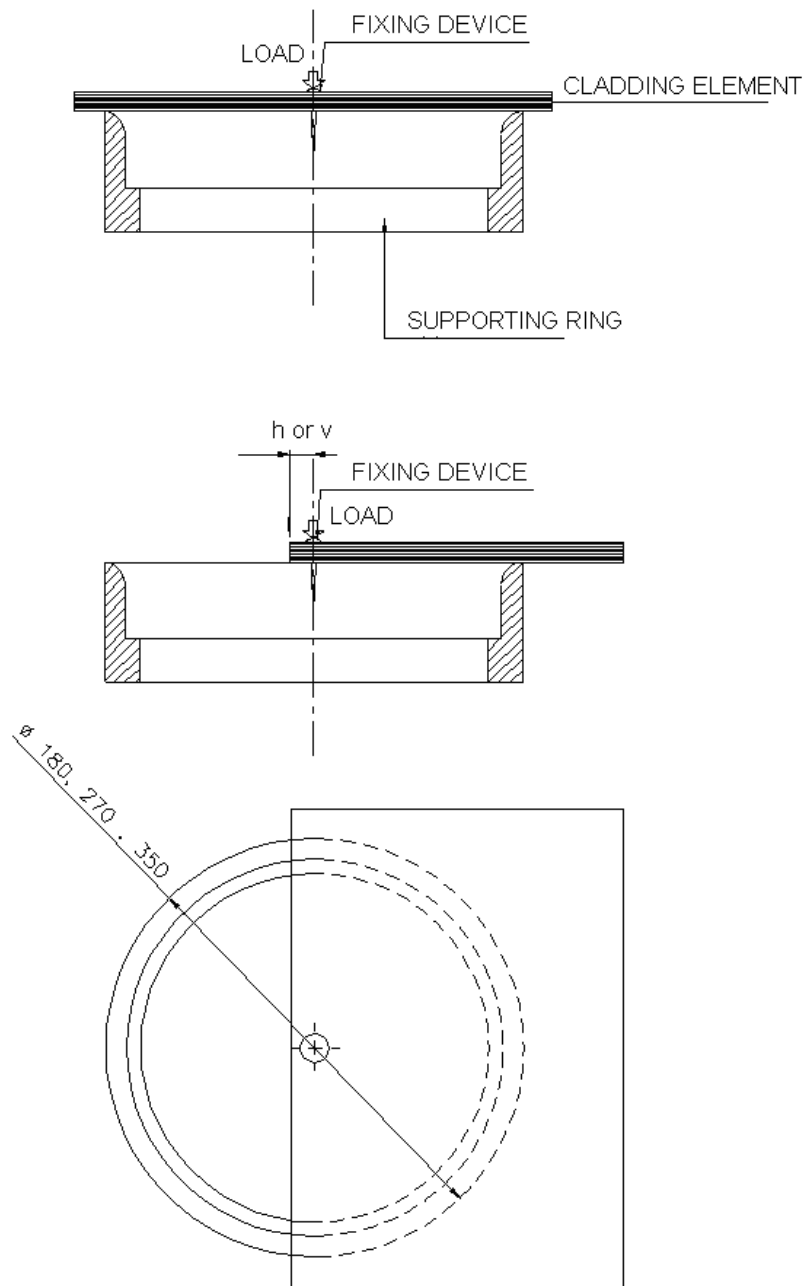

**Figure 7 - Example of test on fixing in edge and centre**

For each implantation (centre, middle and corner) and each ring, at least 5 tests shall be carried out.

The results are expressed in N.

The test report shall detail the following in accordance with Annex D:

- Each  $F_{I, i}$  value
- The mean  $F_{I, m}$  value
- The characteristic  $F_{I, c}$  value giving 75 % confidence that 95 % of the test results will be higher than this value
- The mode of failure description.

5.4.2.1.2 Pull-through resistance under shear loads

Sample strips are mechanically fixed to a wooden batten or a metal profile with one fixing. On specimens of the cladding and substructure at least 5 shear tests each according to Figure 8 shall be carried out.

**When testing, the edge distances  $a_{min}$  and  $b_{min}$  (according to figure 8) shall be conform to the smallest edge distances intended to be used for the cladding kit.**

On the test specimens with the lowest ultimate loads the number of tests shall be supplemented so that for a statistical evaluation at least 7 test results are available.

For fixings of parts of the exterior wall cladding which have nearly the same stiffness, the tests shall be performed according to Figure 8.c).

If a part is almost rigid in comparison with the other, the tests shall be performed according to Figure 8.d).

If the relative stiffnesses are between those requiring tests to Figure 8.c) and 8.d), then both tests shall be carried out.

The speed rate shall be adjusted to 5 mm/min.

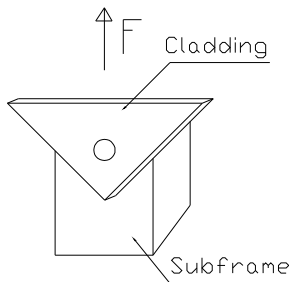

a) view

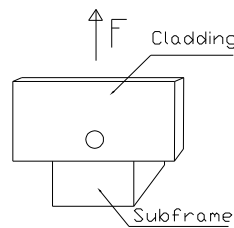

b) view

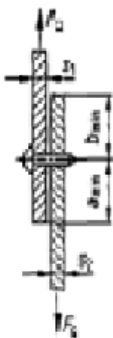

c) section, case 1

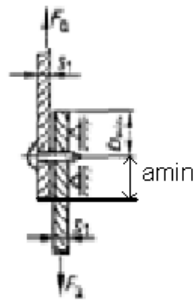

d) section, case 2

<p><math>F_Q</math>: shear force  <math>a_{min}</math>: smallest intended edge distance of the cladding  <math>b_{min}</math>: smallest intended edge distance of the subframe  <math>s_1</math>: thickness of the cladding  <math>s_2</math>: thickness of the subframe</p>
--

**Figure 8 - Examples of shear load test**

The failure load in N and the deformation at failure is measured.

The test report shall detail the following in accordance with Annex D:

- Each  $F_S$ , value
- The mean  $F_S$ , value
- The characteristic  $F_{S C}$  value giving 75 % confidence that 95 % of the test results will be higher than this value
- the measured deformation at failure
- The mode of failure description.

#### 5.4.2.2 Family B

For the tests to be performed, every façade panel is fixed with at least four special anchors placed in a rectangular pattern.

The failure load in N and the deformation at failure is measured.

The test report shall detail the following in accordance with Annex D:

- Each  $F_B$ , value
- The mean  $F_B$ , value
- The characteristic  $F_{B C}$  value giving 75 % confidence that 95 % of the test results will be higher than this value
- The mode of failure description.

#### 5.4.2.2.1 Axial tension test with varying diameter of support

The tests shall be carried out under normal environmental conditions on panel sections with single anchors without edge and spacing effects.

The diameter of the supporting ring shall be changed (for example between  $\varnothing 50$  and 350 mm) in order to find out the diameter  $d_{ref}$  where the failure mode changes from pull-out of the fixing element or cone failure to bending failure of the test specimen (Figure 9).

The test series shall be evaluated separately for each diameter. For each test series at least 5 tests shall be performed.

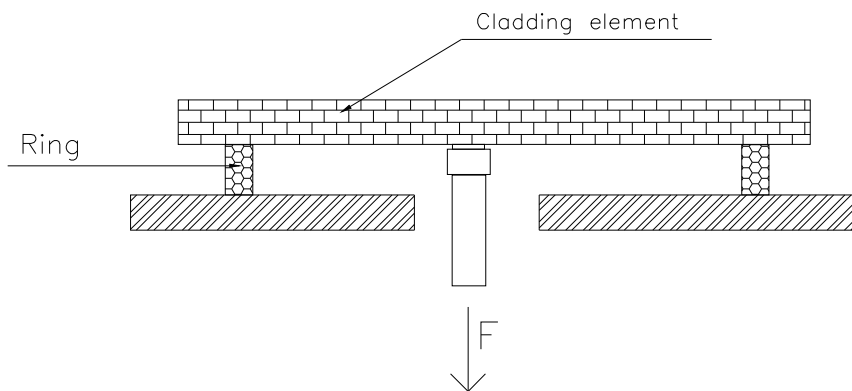
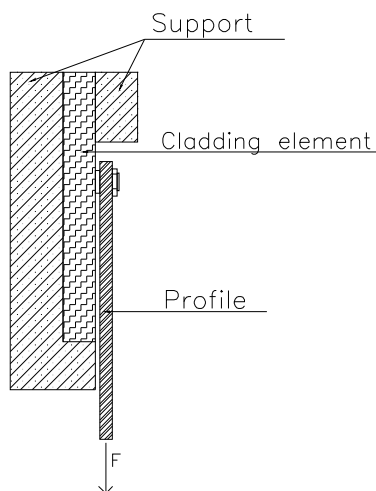

**Figure 9 – Example of test of fixing**

#### 5.4.2.2.2 Shear test

The tests shall be carried out under normal environmental conditions on panel sections with single anchors without edge and spacing effects.

The special anchor shall be installed as specified by the applicant. The shear load shall be applied on the fixing without eccentricity and without exposure to moments (Figure 10).



**Figure 10 - Example of test of fixing**

The loading speed shall be adjusted so that the failure occurs in 1 minute +/- 30 seconds.

Per test series at least 5 tests shall be performed.

#### 5.4.2.2.3 Tests with combined tension and shear loading

The tests shall be carried out under normal environmental conditions on panel sections with single anchors without edge and spacing effects.

The special anchor shall be installed as specified by the applicant.

The direction of load shall correspond to an angle of 30° and 60° relative to the plane of the panel (Figure 11).

The diameter of the supporting ring shall be changed (for example between Ø 50 and 350 mm) in order to find out the diameter  $d_{ref}$  where the failure mode changes from pull-out of the fixing element or cone failure to bending failure of the test specimen

Per test series at least 5 tests shall be performed.

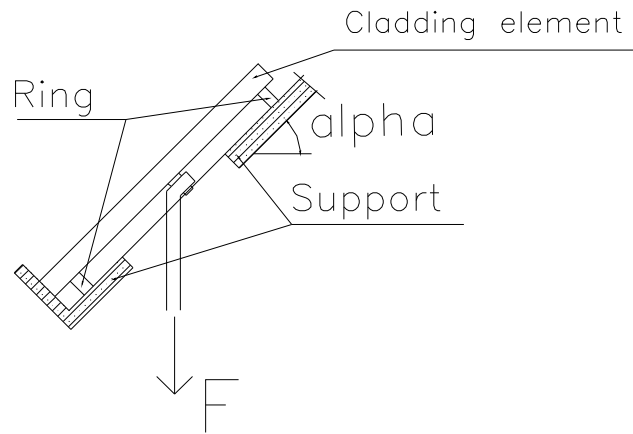

**Figure 11 - Example of test of fixing**

5.4.2.3 Family C

5.4.2.3.1 Resistance of grooved cladding element

The test is performed in ambient conditions.

Samples with a fitting are applied to a rigid substrate as show in Figure 12.

A force is exerted, at a speed rate of 5 mm/min on the profile. The force is applied by pulling the head of the profile. If brackets are used (instead of profile), then the length (L) of the brackets may be < 100 mm.

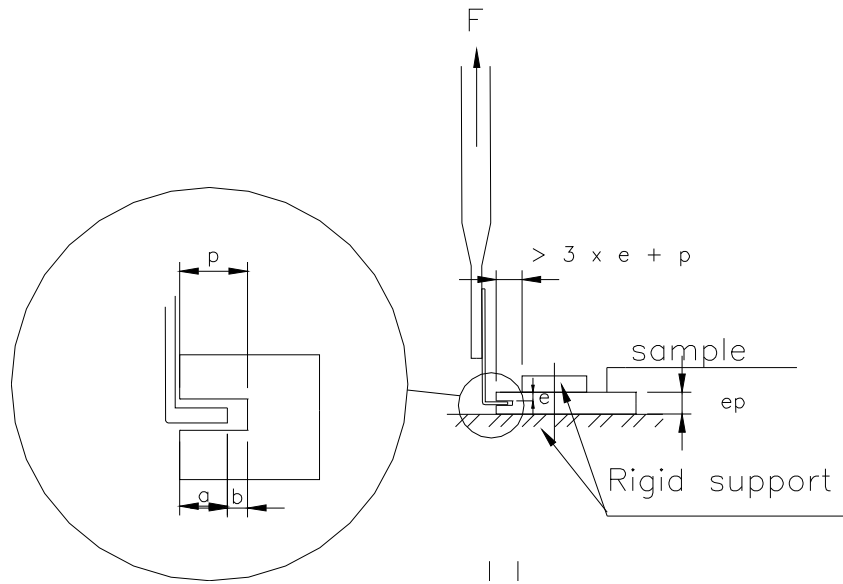

a and b depend on kit, material, fabrication tolerances

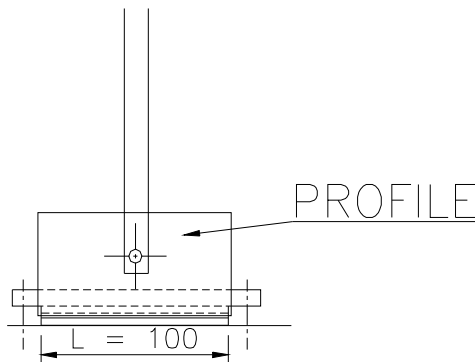

**Figure 12 - Example of test of fixing**

A minimum of 5 tests shall be carried out.

The results are expressed in N.

The test report shall detail the following in accordance with Annex D:

- Each  $F_f$  value
- The mean  $F_f$  value
- The characteristic  $F_{fC}$  value giving 75 % confidence that 95 % of the test results will be higher than this value
- The mode of failure description.

#### 5.4.2.3.2 Resistance of stone at the dowel hole

When the cladding material is natural stone, the breaking load at the dowel hole shall be determined in accordance with EN 13364.

#### 5.4.2.3.3 Resistance to vertical load

This test is performed in ambient conditions.

The cladding kit is fixed to the wall, in accordance with the manufacturer's instructions.  
 The deflection of the profile shall be measured.  
 One cladding element is installed on the profile and an additional dead load equivalent to two cladding elements is added, on top of the first one.  
 The test can be stopped if the deflection is less than 0.1 mm after 1 hour.  
 The test result is a deflection curve as a function of the time and the maximum deflection.

#### 5.4.2.3.4 Pull-through resistance of fixings from profiles

This test establishes the pull-through resistance of an anchor through the perforation in the profile.

The test is carried out on at least 5 samples each measuring 300 mm ± 20 mm and perforated in the centre, using a drilled hole.

The apparatus consists of:

- A dynamometer,
- A support and metal screw as shown in Figure 13.

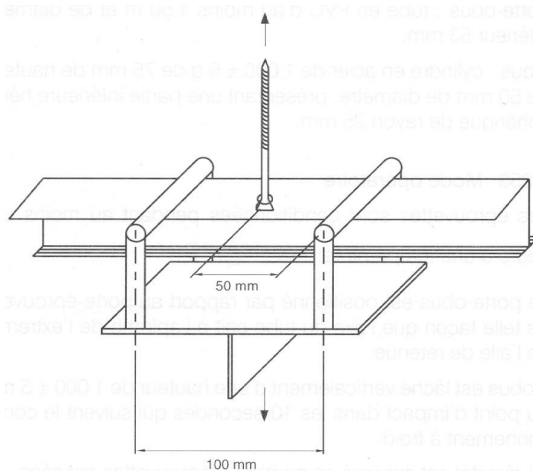

**Figure 13 - Example of test**

The samples are conditioned for at least 2 h at (23 ± 2) °C before the test.

The screw is placed perpendicular to the profile as described in Figure 13.

The test is carried out at (23 ± 2) °C using a tensioning speed of 20 mm/min.

The pull-through resistance is expressed in N.

The test report shall detail the following in accordance with Annex D:

- Each  $R_S$ , value
- The mean  $R_S$ , value
- The characteristic  $R_{SC}$  value giving 75 % confidence that 95 % of the test results will be higher than this value
- The mode of failure description.

#### 5.4.2.4 Family D

##### 5.4.2.4.1 Pull-through resistance of cladding element

The test is performed in ambient conditions.

Samples, length 200 mm at least, with a fixing are applied to a supporting ring as show in Figure 14. The diameter depends on the material of the sample. It shall be about 50 mm.

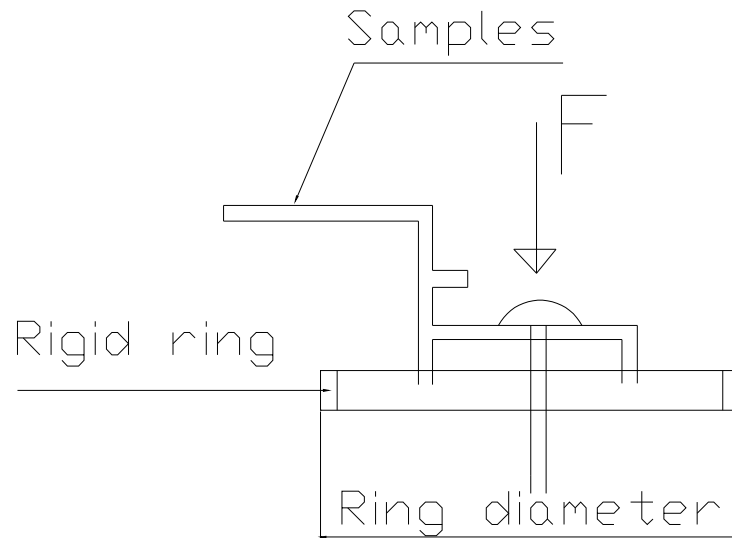

**Figure 14 - Example of test of fixing**

A force is exerted, at a speed rate of 10 mm/min on the anchor through the cladding element until failure. The force can be applied either by pushing on the head of the anchor or pulling the end of the anchor.

A minimum of 5 tests shall be carried out.

The results are expressed in N.

The test report shall detail the following in accordance with Annex D:

- Each  $F_S$ , value
- The mean  $F_S$ , value
- The characteristic  $F_{SC}$  value giving 75 % confidence that 95 % of the test results will be higher than this value
- The mode of failure description.

#### 5.4.2.4.2 Resistance of grooved cladding element

This requirement is considered in the paragraph 5.4.2.3.1.

#### 5.4.2.4.3 Pull-through resistance under shear loads

This requirement is considered in the paragraph 5.4.2.1.2.

#### 5.4.2.5 Family E

##### 5.4.2.5.1 Pull-through resistance of cladding element

This requirement is considered in the paragraph 5.4.2.4.1.

##### 5.4.2.5.2 Pull-through resistance under shear loads

This requirement is considered in the paragraph 5.4.2.1.2.



#### 5.4.2.6 Family F

##### 5.4.2.6.1 Resistance of metal clip

The test is performed in ambient conditions.

Metal clips are applied to a rigid substrate as show in Figure 15.

A force is exerted, at a speed rate of 5 mm/min on the metal clip.

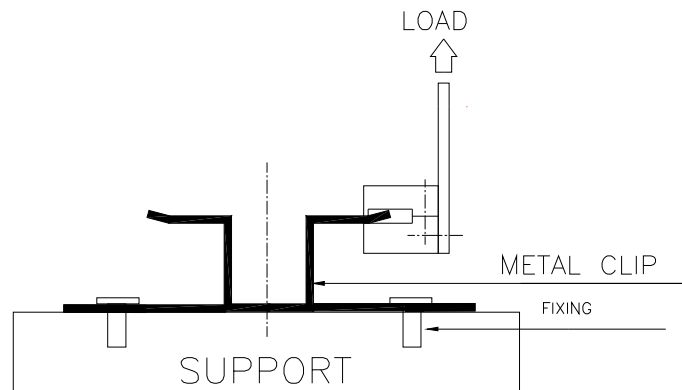

**Figure 15 - Example of test of metal clip**

The test is performed in successive steps with a return to zero at each level, until 1 mm irreversible deformation occurs.

The test is then continued until failure occurs.

The deflection shall be measured and reported in tabular or graphic form.

At least 5 tests shall be carried out.

The results are expressed in N.

The test report shall detail the following in accordance with Annex D:

- Each  $F_{mc}$  value for 1 mm irreversible deformation
- The mean  $F_{mcs}$  value
- The characteristic  $F_{mcSC}$  value giving 75 % confidence that 95 % of the test results will be higher than this value
- The mode of failure description

##### 5.4.2.6.2 Resistance to vertical load

This test is performed in ambient conditions.

The cladding kit is fixed to the wall, in accordance with the manufacturer's instructions which specify also the type of wall.

The deflection of the profile shall be measured.

One cladding element is installed on the profile and an additional dead load equivalent to two cladding elements is added, on top of the first one.

The test can be stopped if the deflection is less than 0.1 mm after 1 hour.

The test result is a deflection curve as a function of the time and the maximum deflection.

#### 5.4.2.7 Family G

##### 5.4.2.7.1 Resistance of slot

The test is performed in ambient conditions.

Samples with notch are applied to a rigid substrate as show in Figure 16.

A force is exerted, at a speed rate of 5 mm/min on the cladding element's fixing until failure.

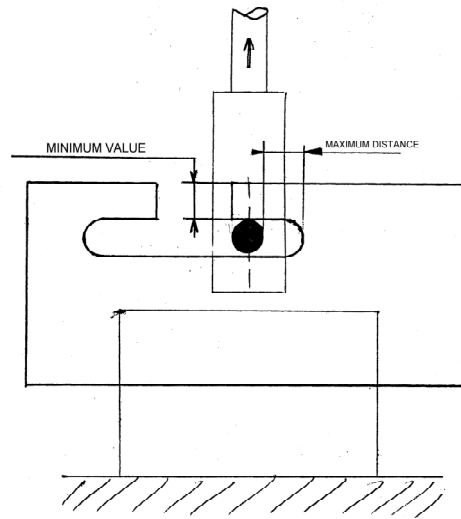

**Figure 16 - Example of slot test**

A minimum of 5 tests shall be carried out.

The results are expressed in N.

The test report shall detail the following in accordance with Annex D:

- Each  $F_n$  value
- The mean  $F_{ns}$  value
- The characteristic  $F_{nsc}$  value giving 75 % confidence that 95 % of the test results will be higher than this value
- The mode of failure description

Note : In case of a doubt on a resistance of dead load or in case of anti-lift up, a test in the vertical direction of the cassette may be performed.

#### 5.4.2.8 Family H

If the cladding elements are fixed by nails or screws, the through cladding element test in according with § 5.4.2.4.1 and pull-through resistance under shear loads tests in according with § 5.4.2.1.2 are performed.

If the cladding elements are fixed by metal clip, the test in according with § 5.4.2.6 is performed.

#### 5.4.3 Resistance to horizontal point loads

Where required, the behaviour when tested for horizontal static load in service (ladder bearing against it) shall be checked.

The cladding kit shall be capable of accommodating the horizontally applied loads acting on its surface arising from maintenance without any reduction in its performances.

The cladding shall sustain safely, without reduction in performance and without permanent deformation to any component, a static 500 N load applied one minute horizontally through two squares of 25 x 25 x 5 mm spaced apart (distance 440 mm) on any part of the surface of the cladding (one person standing on a ladder leaning against the surface of the cladding) at room temperature.

#### 5.4.4 Impact resistance

The verification method proposed in this ETAG is similar to the EOTA Technical Report TR001 – Edition February 2003.

##### 5.4.4.1 Resistance to hard body impact

Hard body impact tests are performed as described in ISO 7892: 1988. The points of impact are selected taking into account various modes of behaviour of walls and their cladding, varying according to whether the impact point is or is not located in an area of greater rigidity (At less than 50 mm from the edge of cladding element).

Hard body impacts (10 Joules) are carried out with the steel ball weighing 1 kg and from a height of 1.02 m (At least three locations).

Hard body impacts (1 to 3 Joules) are carried out with the steel ball weighing 0.500 kg and from a height of 0.20 to 0.61 m (At least three locations).

##### Observations:

The presence of any micro cracks or cracks, at the impact point and at the circumference, is noted. The area of the cracked zone is measured and noted. The nature of any breakage (e.g. sharp points or edges) is described.

##### 5.4.4.2 Resistance to soft body impact

Soft body impact tests are performed as described in ISO 7892: 1988. The points of impact are selected taking into account various modes of behaviour of walls and their cladding, varying according to whether the impact point is or is not located in an area of greater rigidity (At less than 50 mm from the edge of cladding element).

Soft body impacts (10 to 60 Joules) are carried out with the ball weighing 3 kg and from a height of 0,34 to 2.04 m (At least three locations).

Soft body impacts (300 to 400 Joules) are carried out with the ball weighing 50 kg and from a height of 0,61 to 0.82 m (At least in the centre point of a cladding element).

##### Observations:

- The area of the crack zone is measured and noted,
- The presence of any micro cracks or cracks, at the impact point and at the circumference, is noted.

#### 5.4.5 Resistance to seismic actions

European and/or National regulations are applied.

#### 5.4.6 Hygrothermal behaviour

This test is required only for cladding kits, that are known to be or suspected of being sensitive to hygrothermal variation.

##### Preparation of the rig

- The kit is applied, in accordance with the manufacturer's instructions, to a sufficiently stabilised masonry substrate (minimum 28 days).
- The kit may be applied to the lateral faces of the supporting wall and in its corners.
- The installation details (quantities of material applied, position of the joints between elements, fixing devices, etc ...), have to be checked and registered by the laboratory.
- The dimensions of the rig shall be:
  - Surface  $\geq 6 \text{ m}^2$
  - Width  $\geq 2.50 \text{ m}$
  - Height  $\geq 2.00 \text{ m}$

##### Method of operation

The test apparatus is positioned against the front face of the rig at 0.10 to 0.30 m from the edges.

The specified temperatures during the cycles are measured at the surface of the rig. The regulation shall be obtained by warm air.

##### Heat - rain cycles

The rig is subjected to a series of 80 cycles, comprising the following phases:

- 1 - Heating to + 70 °C (rise for 1 hour) and maintaining at (+ 70  $\pm$  5) °C and 10 to 30 % RH of air for 2 hours (total of 3 hours),
- 2 - Spraying for 1 hour (water temperature (+ 15  $\pm$  5) °C, amount of water 1 l/m<sup>2</sup> min),
- 3 - Leave for 2 hours (drainage).

##### Heat-cold cycles

After at least 48 hours of subsequent conditioning at temperatures between + 10 and + 25 °C and a minimum relative humidity of 50 %, the same test rig is exposed to 5 heat/cold cycles of 24 hours comprising the following phases:

- 1 - Exposure to (+ 50  $\pm$  5) °C (rise for 1 hour) and maximum 30 % RH of air for 7 hours (total of 8 hours),
- 2 - Exposure to (- 20  $\pm$  5) °C (fall for 2 hours) for 14 hours (total of 16 hours).

##### Observations during the test

At periods of every four cycles during the heat/rain cycles and at every cycle during the heat/cold cycles, observations relating to a change in characteristics or performance (blistering, detachment, loss of adhesion, bowing, formation of cracks, efflorescence, , etc ...) are recorded as follows:

- The surface finish of the kit is examined to establish whether any cracking has occurred. The dimensions and position of any cracks shall be measured and recorded,
- The surface shall also be checked for any blistering or peeling and the location and extent shall again be recorded,
- The sills and profiles shall be checked for any damage/degradation together with any associated cracking of the cladding. Again, the location and extent shall be recorded.

Following the completion of the test, a further investigation is conducted involving removal of sections to observe any water penetration within the kit.

## 5.5 ER5 Protection against noise

This requirement is not relevant to Part I.

## 5.6 ER6 Energy economy and heat retention

This requirement is not relevant to Part I.

## 5.7 Aspects of durability and serviceability

For new material and material not commonly used for this application, supplementary durability tests may have to be defined. The summary of assessment shall describe the details of test and the result obtained, case by case.

Durability of self-supporting composite lightweight panels covered by ETAG 016 shall be assessed according to methods defined in that Guideline or according to a related specific TR.

### 5.7.1 Pulsating load

For family B, the test shall be done as follow:

The tests shall be carried out under normal environmental conditions on panel sections with cladding fixing without edge and spacing effects. The diameter of the supporting ring shall be chosen from the test series according to § 5.4.2.2.1 where the failure mode changed from pull-out of the fixing element to bending failure of the test specimen ( $d_{ref}$  according to § 5.4.2.2.1).

The cladding fixing shall be exposed to 10 000 load cycles at a frequency of 2 to 6 Hz. The upper load  $F_{max}$  and the lower load  $F_{min}$  shall be chosen accordingly. the following loads can be considered as appropriated: upper load  $F_{max} = 50 \% \times F_{u,5\%}$ ; lower load  $F_{min} = 20 \% \times F_{u,5\%}$  ( $F_{u,5\%}$  = characteristic value determined according to Annex D for the results of the tension tests according to § 5.4.2.2.1 for  $d_{ref}$ ).

During each cycle the load shall vary like a sine curve between  $F_{max}$  and  $F_{min}$ . The displacement shall be measured during the first loading up to  $F_{max}$  and either continuously or at least after 1, 10, 100, 1000 and 10 000 load cycles.

After completion of the load cycles the anchor shall be unloaded, the displacement measured and a tension test performed as indicated in § 5.4.2.2.1.

At least 5 tests shall be performed.

For other families, the principle of pulsating load test as defined above can be applied, if relevant, to the test described in § 5.4.2.

## 5.7.2 Dimensional stability of external cladding

Where necessary, the dimensional stability shall be determined in accordance with one of the following Standards:

- for Fibre cement : EN 12467
- for the composite cement glass : EN 1170-7
- for the PVC : EN 13245-2
- for the laminates panels : §17 of EN 438-2
- for the wood based panels : EN 318
- for ceramics : EN ISO 10545-8 or 10
- for stone EN 14581
- for aluminium: EN 1999-1-1
- For the other materials, assessment shall be according to an appropriate ISO or European Standard, in their absence, to a procedure developed within EOTA.

## 5.7.3 Immersion in water

For cladding material likely to be susceptible to water penetration, the immersion in water sensitivity is required in accordance with Annex C. For specific material sensitive to immersion in water, but not covered by EN standard according to Annex C, an internal procedure may be applied and a bending test (according to Annex C) is made before and after cycles.

For family B, the test shall be done as follow:

The tests shall be carried out under normal environmental conditions on panel sections with single anchors without edge and spacing effects. The diameter of the supporting ring shall be chosen from the test series according to 5.4.2.2.1 where the failure mode changed from pull-out of the fixing element to bending failure of the test specimen.

The test specimens shall be immersed in water until constant mass is achieved. Then axial tension tests are carried out as indicated in 5.4.2.2.1.

At least 5 tests shall be performed.

For other families, the principle of the immersion in water test as defined above can be applied, if relevant, to the test described in § 5.4.2.

## 5.7.4 Freeze-thaw

For cladding materials likely to be susceptible to frost, the freeze-thaw sensitivity is required in accordance with Annex C. For specific material sensitive to freeze-thaw, but not covered by an EN standard according to Annex C, an internal procedure may be applied and bending test (according to Annex C ) is made before and after cycles.

For family B, the test shall be done as follow:

The tests shall be carried out under normal environmental conditions on panel sections with single anchors without edge and spacing effects. The diameter of the supporting ring shall be chosen from the test series according to 5.4.2.2.1 where the failure mode changed from pull-out of the fixing element to bending failure of the test specimen ( $d_{ref}$  according to 5.4.2.2.1).

The number of cycles required depends on the geographical zones the manufacturer wants to be covered by the ETA. The following options may be used: 0 freeze-thaw cycles (option 0); 25 freeze-thaw cycles (option 1); 50 freeze-thaw cycles (option 2). The test specimens shall be immersed in water and then subjected to freeze-thaw cycles. The type and duration of the freeze-thaw regime shall be decided by the relevant Approval Body and stated in the ETA.

After completion of freeze-thaw cycles a tension test shall be performed as indicated in 5.4.2.2.1.

At least 5 tests shall be performed.

For other families, the principle of the freeze-thaw test as defined above can be applied, if relevant, to the test described in § 5.4.2.

### 5.7.5 Chemical and biological resistance

The test is required for claddings with a cladding product known to be sensitive to chemical and biological attack such as wood based panel, plastics, stone or laminates.

To assess the chemical and biological attack, the approval body will make reference to a European Standard as appropriate:

- To assess the durability of wood based panels and solid wood:
  - EN 321 Wood based panels – Determination of moisture resistance under cyclic test conditions
  - EN 335-1 Durability of wood and wood based products – Definition of hazard classes of biological attack – Part 1: General
  - EN 335-2 Durability of wood and wood based products – Definition of hazard classes of biological attack – Part 2: Application to solid wood
  - EN 335-3 Durability of wood and wood based products – Definition of hazard classes of biological attack – Part 3: Application to wood based panels
  - EN 350-2 Durability of wood and wood based products – Natural durability of solid wood – Part 2: Guide to natural durability and treatability of selected wood species of importance in Europe
  - EN 351-1 Durability of wood and wood based products – Preservative-treated solid wood – Part 1: Classification of preservative penetration and retention
  - EN 460 Durability of wood and wood based products – Natural durability of solid wood – Guide to the durability requirements for wood to be used in hazard classes

- EN 599-1 Durability of wood and wood based products – Performance of preventive wood preservative as determined by biological tests – Part 1: Specification according to hazard class
- EN 599-2 Durability of wood and wood based products – Performance of preventive wood preservative as determined by biological tests – Part 2: Classification and labelling
- To assess the durability of laminates :
  - EN 438-7 High pressure decorative laminates (HPL)
- To assess the durability of plastics :
  - ISO 846 Plastics – Methods of assessing of microorganism action
- To assess the durability of stone :
  - EN14147 Natural stone test methods – Determination of resistance to ageing by salt mist

## 5.7.6 Corrosion

### 5.7.6.1 Cladding element made of steel, steel alloys or stainless steel

The cladding element made of metal and its corrosion protection will be defined according to the following standards:

- EN 10020 Definition and classification of grades of steel
- EN 10346 Continuously hot-dip coated steel flat products– Technical delivery conditions
- EN 10169 Continuously organic coated (coil coated) steel flat products – Technical delivery conditions
- \* EN 10088-1 Stainless steels – Part 1: List of stainless steels
- \* EN 10088-2 Stainless steels – Part 2: Technical delivery conditions for sheet/plate and strips for general purposes

### 5.7.6.2 Cladding element made of aluminium or aluminium alloys

The cladding element made of metal and its corrosion protection will be defined according to the following standards:

- \* EN 485-2 Aluminium and aluminium alloys – Sheet, strip and plate – Part 2: Mechanical properties
- \* EN 573-3 Aluminium and aluminium alloys – Chemical composition and form of wrought product – Part 3: Chemical composition
- \* EN 755-1 Aluminium and aluminium alloys – Extruded rod/bar, tube and profiles
  - Part 1: Technical conditions for inspection and delivery



- \* EN 755-2 Aluminium and aluminium alloys – Extruded rod/bar, tube and profiles - Part 2: Mechanical properties
- \* EN 1396 Aluminium and aluminium alloys – Coil coated sheet and strip for general applications – Specification
- \* EN 1999-1-1 Design of aluminium structures, part 1-1: General structural rules
- \* EN 13523-10 Coil coated metals — Test methods — Part 10: Resistance to fluorescent UV light and water condensation

### 5.7.6.3 Cladding fixings

To assess the corrosion of cladding fixings, the approval body will make reference to the following European Standards:

- \* EN ISO 898-1 Mechanical properties of fasteners made of carbon steel and alloy steel – Part 1: Bolts, screws and studs.
- \* EN ISO 3506-1 Mechanical properties of corrosion-resistant stainless-steel fasteners – Part 1: Bolts, screws and studs.
- \* EN 1670 Building hardware – Corrosion resistance – Requirements and test methods

The steel grade has to be defined as a function of the field of application (e.g. marine atmosphere or industrial atmosphere).

In particularly aggressive atmosphere with extreme chemical pollution (e.g. desulphurisation plants, chloride atmosphere), special measures of corrosion protection shall be foreseen.

If the cladding fixing is to be used in particularly aggressive atmosphere with extreme chemical pollution (e.g. in desulphurization plants or chloride atmosphere) the execution of corresponding tests will be required taking account of the relevant environmental conditions and of current experience.

### 5.7.7 UV radiation

The test is required for claddings with a cladding product known to be sensitive to UV radiation such as polyester or other plastics.

The approval body will make reference, for the methods of exposure to laboratory light sources, to the following standards:

- \* ISO 877-3 Plastics – Methods of exposure to direct weathering, to weathering using glass-filtered daylight, and to intensified weathering by daylight using Fresnel mirrors
- \* ISO 877 -1, 2, 3 Plastics – Methods of exposure to natural weathering

- \* EN ISO 4892-1 Plastics – Methods of exposure to laboratory light sources – Part 1: General guidance
- \* EN ISO 4892-2 Plastics – Methods of exposure to laboratory light sources – Part 2: Xenon-arc sources
- \* EN ISO 4892-3 Plastics – Methods of exposure to laboratory light sources – Part 3: Fluorescent UV lamps
- \* EN ISO 4892-4 Plastics – Methods of exposure to laboratory light sources – Part 4: Open-flame carbon-arc lamps
- \* EN 927-2 Paints and varnishes coating material and coating systems for exterior wood – Part 2 : Performance specification
- \* EN 13245-2 Plastics – unplasticized poly(vinyl chloride) (PVC-U) profiles for building applications – Part 2: Products for internal and external wall and ceiling finishes
- \* EN 10169 Continuously organic coated (coil coated) steel flat products – Technical delivery conditions

After ageing test, the approval body shall assess the evolution of the characteristics by identification test (e.g. Modulus of elasticity, hardness) as described in Annex C.

## 6 ASSESSING AND JUDGING THE FITNESS FOR USE

### Preamble

This chapter details the performance requirements to be met by a cladding (chapter 4) in precise and measurable (as far as possible and proportional to the importance of the risk) or qualitative terms, related to the products and their intended use, using the verification methods (chapter 5).

Each performance requirement to be met for a given intended use, is assessed for classes, use categories or numerical values. The ETA shall indicate either the results of these assessments or state « No performance determined » (for countries/regions/buildings where no requirements given in laws, regulations and administrative provisions are applicable). This statement does not mean that the cladding performs badly, but merely that this specific performance property has not been tested and assessed.

For results outside the requirements given below, the approval body shall subject them to a deeper analysis based on a larger number of test pieces, repeating any questionable tests or other measurements related to the problem concerned.

**Table 3 - Relationship between kit and component performance to be assessed and expressions of classification, categorisation and declaration.**

ER	ETAG paragraph on product performance to be assessed	Class, use category, criterion	« No Performance Determined Option » allowed
1	-	-	-
2	6.2.1 Reaction to fire	Euroclasses A <sub>1</sub> to F	YES (Class F)
	6.2.2 Reaction to fire on rear side	Euroclasses A <sub>1</sub> to F	YES (Class F)
	6.2.3 fire resistance	Not relevant	-
3	6.3.1 Watertightness of joints	Pass/fail and Value of air pressure	YES
	6.3.2 Waterpermeability	Not relevant*	-
	6.3.3 Water vapour permeability	Not relevant*	-
	6.3.4 Drainability	Pass/fail	YES
	6.3.5 Release of dangerous substances	Indication of dangerous substances incl. concentration etc. "No dangerous substances"	YES
4	6.4.1 Wind load resistance	Resistance	NO
	6.4.2 Mechanical resistance	Resistance	NO
	6.4.3 Resistance to horizontal points load	Pass/fail	YES
	6.4.4 Impact resistance – shatter properties	Categories I, II, III or IV	YES
	6.4.5 Resistance to seismic actions	European or national regulations	YES
	6.4.6 Hygrothermal behaviour	Pass/fail	YES

5	6.5 Protection against noise	Not relevant*	-
6	6.6 Energy economy and heat retention	Not relevant*	-
Aspects of durability and serviceability	6.7.1 Pulsating load	Value	YES
	6.7.2 Dimensional stability of external cladding element	Value	YES
	6.7.3 Immersion in water	Value	YES
	6.7.4 Freeze-thaw	Pass/fail and number of cycles	YES
	6.7.5 Chemical and biological attack	Pass/fail	YES
	6.7.6 Corrosion	Pass/fail	YES
	6.7.7 UV radiation	Pass/fail	YES

\* Not relevant in Part I of this guide

## 6.1 Mechanical resistance and stability

Not relevant

## 6.2 Safety in case of fire

### 6.2.1 Reaction to fire

Cladding kit and its components shall be classified according to EN 13501-1(2007) (to be applied in accordance with the provision of relevant EC Decision).

Where all components of the kit are class A1 without testing according to Decision 96/603/EEC as amended, the whole kit may be classified Class A1 without testing. Where one or more of the components is classified according to a CWFT Decision, the whole kit may be classified to the lowest class of any component.

It shall be indicated that, since the cladding kit has not been assessed according to façade fire scenarios, an additional demonstration of the fitness for use in this context could have to be given in some countries at national level, as long as the harmonised system is not available.

### 6.2.2 Reaction to fire on rear side

Cladding kit and its components are classified according to EN 13501-1(2007) Fire classification of construction products and building elements – Part 1: Classification using test data from reaction to fire tests (to be applied in accordance with the provision of relevant EC Decision).

Where all components of the kit are class A1 without testing according to Decision 96/603/EEC as amended, the whole kit may be classified Class A1 without testing. Where one or more of the components is classified according to a CWFT Decision, the whole kit may be classified to the lowest class of any component.

### 6.2.3 Fire resistance

Not relevant

## 6.3 Hygiene, health and the environment

### 6.3.1 Watertightness of joints

Two requirements shall be satisfied for the intended working life of the kit:

- \* Water running down the wall shall not reach the inside face of the wall
- \* Materials likely to be adversely affected by water (adhesives, insulation fixings subject to corrosion, etc) shall not become damp.

The degree of watertightness of a cladding kit can be generally assessed by appraisal of design, taking account of the characteristics of the materials used and the geometry of external cladding element and joints.

The Approval Body will assess the watertightness of joints for kits intended to be watertight. In case of doubt, an artificial rain test shall be carried out the cladding kit in accordance with EN 12865 Procedure A (600 Pa maximum). The level of pressure just before water penetration is given in the ETA.

Note: the use of a given type of cladding system will depend on the severity of the climate and its exposition with regard to the supporting wall.

### 6.3.2 Water permeability

Not relevant to Part I.

### 6.3.3 Water vapour permeability

Not relevant to Part I.

### 6.3.4 Drainability

The drainability of water in the kit shall be visually assessed.

### 6.3.5 Release of dangerous substances

The product/kit shall comply with all relevant European and national provisions applicable for the uses for which it is brought to the market. The attention of the applicant shall be drawn on the fact that for other uses or other Member States of destination there may be other requirements which would have to be respected. For dangerous substances contained in the product but not covered by the ETA, the NPD option (no performance determined) is applicable.

#### Used wood

If used wood has been used for the production of wood-based panels, "Use of used wood – yes» shall be stated.

#### Biocides

The used biocide(s) has/have to be declared stating the trade name of the biocide(s), the chemical name(s) of the active component(s), the amount(s) and the technical procedure of application.

Alternatively for wood preservatives a marking "PT"(treated with wood preservatives) according EN 13986 is possible.

#### Flame retardant/fire retardant

A declaration of the flame/fire retardant, the amount and the state of the treatment has to be given. A declaration, that no polybrominated diphenylether is used, has to be given.

#### Formaldehyde

If relevant, the products shall comply with the emission classes according to Annex B of EN 13986 for wood based panels and according to EN 438-7 for laminates.

Note: For some Member State formaldehyde emitting products above class E1 (< 0,124 mg/m<sup>3</sup> in application of the measurement method foreseen in the relevant standard) are prohibited.

#### Pentachlorophenol:

If relevant, the concentration shall be given in ppm or mg/kg.

Note: For some Member States, products which contain more than 5 ppm PCP are prohibited.

#### Man made mineral fibres

A declaration of the carcinogenic potential of the fibers used has to be given according the test methods/verification methods described in 4.3 by indication, if method I or II was used.

Note: For some Member State, a declaration of carcinogenic potential according method I is mandatory.

#### Ceramic fibres

If appropriate, a declaration, that ceramic fibres are used shall be given.

#### Cadmium

The content of cadmium contained in plastics, paints, lacquers, varnishes, zinc or zinc coatings shall be given. If cadmium or a cadmium compound is used as a coating this shall be declared.

Note 1: CE-marked products containing cadmium above a certain concentration are prohibited on the market in at least one Member State.

## 6.4 Safety in Use

### 6.4.1 Wind load resistance

The appraisal is based on data from the wind suction and wind pressure tests (see §5.4.1) and mechanical tests (see § 5.4.2).

The most critical case (see §5.4.1) shall be explained in the ETA (tolerance due to manufacturing and/or installation and deformation due to temperature and humidity variations). If the characteristic wind resistance Q5% is calculated from the results of the mechanical tests, the calculation method and the calculated value shall be defined in the ETA.

If the characteristic wind resistance Q5% is calculated from the suction/pressure tests, the calculated value shall be declared in the ETA.

#### 6.4.1.1 Wind suction

The load Q for which the test specimen fails, the type of failure and the value of maximum deflection, shall be indicated in the ETA.

In addition, the points of measurement shall be indicated on a drawing of the test specimen and the deflections at each measurement point shall be tabulated for each suction step.

#### 6.4.1.2 Pressure

The load Q for which the test specimen fails, the type of failure and the value of maximum deflection, shall be declared in the ETA, if the test was performed.

In addition, the points of measurement shall be indicated on a drawing of the test specimen and the deflections at each measurement point shall be tabulated for each pressure step.

### 6.4.2 Mechanical resistance

The characteristic value of pull-out and shear resistance of screws, rivets or nails shall be declared according to relevant standard.

#### 6.4.2.1 Family A

For each implantation and each ring, the mean and characteristic value shall be indicated in the ETA.

##### 6.4.2.1.1 Pull through resistance under shear loads

The mean and characteristic value shall be indicated in the ETA.

#### 6.4.2.2 Family B

The following shall be indicated in the ETA:

- The diameter of the supporting ring where failure mode changes from pull-out of the fixing element or cone failure to bending failure of the test specimen.
- The characteristic value giving 75 % confidence that 95 % of the test results will be higher than this value and the mean values of test series.
- The load/displacement curves.

#### 6.4.2.3 Family C

##### 6.4.2.3.1 Resistance of grooved cladding element

The mean and characteristic value shall be indicated in the ETA.

The geometry and the position of the elements during the test shall be given.

##### 6.4.2.3.2 Resistance of stone at dowel hole

The mean and characteristic value in accordance with the standard EN 13364.

#### 6.4.2.3.3 Resistance of vertical load

The Approval Body shall assess if the deformation from dead load is compatible with the cladding kit.

#### 6.4.2.3.4 Pull through resistance of fixings from profiles

The mean and characteristic value shall be indicated in the ETA.

#### 6.4.2.4 Family D

##### 6.4.2.4.1 Through cladding element

The mean and characteristic value shall be indicated in the ETA.

##### 6.4.2.4.2 Resistance of grooved cladding element

The mean and characteristic value shall be indicated in the ETA.

##### 6.4.2.4.3 Pull through resistance under shear loads

The mean and characteristic value shall be indicated in the ETA.

#### 6.4.2.5 Family E

##### 6.4.2.5.1 Through cladding element

The mean and characteristic value shall be indicated in the ETA.

##### 6.4.2.5.2 Pull through resistance under shear loads

The mean and characteristic value shall be indicated in the ETA.

#### 6.4.2.6 Family F

##### 6.4.2.6.1 Resistance of metal clip

The mean and characteristic value shall be indicated in the ETA.

##### 6.4.2.6.2 Resistance of vertical load

The Approval Body shall assess if the deformation from dead load is compatible with the cladding kit.

#### 6.4.2.7 Family G

The mean and characteristic value shall be indicated in the ETA.

#### 6.4.2.8 Family H

The mean and characteristic value shall be indicated in the ETA.



### 6.4.3 Resistance to horizontal point loads

There shall be no permanent deformation (no visible deformation) to any component.

### 6.4.4 Impact resistance – shatter properties

The categories given in the following table correspond to the degrees of exposure in use. They do not include an allowance for acts of vandalism.

**Table 4 - Definition of use categories**

Use category	Description
I	A zone readily accessible at ground level to the public and vulnerable to hard body impacts but not subjected to abnormally rough use.
II	A zone liable to impacts from thrown or kicked objects, but in public locations where the height of the kit will limit the size of the impact; or at lower levels where access to the building is primarily to those with some incentive to exercise care.
III	A zone not likely to be damaged by normal impacts caused by people or by thrown or kicked objects.
IV	A zone out of reach from ground level

The hard body impact with steel ball represents the action from heavy, non-deformable objects, which accidentally hit the kit. Based upon the obtained test results, the kit is assessed as being in category I, II, III or IV as follows.

**Table 5 - Impact Categories**

	Category IV	Category III	Category II	Category I
Test 5.4.4.1 Impact 1 joule	cladding element not cracked <sup>2)</sup>	-----	-----	-----
Test 5.4.4.1 Impact 3 joule	-----	cladding element not cracked <sup>2)</sup>	No deterioration <sup>1)</sup>	No deterioration <sup>1)</sup>
Test 5.4.4.1 Impact 10 joule	-----	-----	Cladding element not cracked <sup>2)</sup>	No deterioration <sup>1)</sup>
Test 5.4.4.2 Impact 10 joule	No deterioration <sup>1)</sup>	No deterioration <sup>1)</sup>	-----	-----
Test 5.4.4.2 Impact 60 joule	-----	-----	No deterioration <sup>1)</sup>	No deterioration <sup>1)</sup>
Test 5.4.4.2 Impact 300 joule	-----	-----	No deterioration <sup>1)</sup>	-----
Test 5.4.4.2 Impact 400 joule	-----	-----	-----	No deterioration <sup>1)</sup>

<sup>1)</sup> Superficial damage, provided there is no cracking, is considered as showing "no deterioration".

<sup>2)</sup> The test result is assessed as being "cracked" if circular cracking penetrating is observed.

The approval body shall establish that the cladding product does not present sharp or cutting edges and its surfaces do not cause bodily injury, to the occupants or people nearby.

#### 6.4.5 Resistance to seismic actions

European and/or National regulation is applied.

#### 6.4.6 Hygrothermal behaviour

The following defects shall neither occur during, nor at the end of the test programme:

- deterioration such as cracking or delamination of the cladding element that allows water penetration to the insulation
- detachment of the cladding element
- Irreversible deformation

#### 6.5 Protection against noise

Not relevant to Part I.

#### 6.6 Energy economy and heat retention

Not relevant to Part I.

#### 6.7 Aspects of durability and serviceability

##### 6.7.1 Pulsating load

The following shall be indicated in the ETA:

- The 5%-fractile values (for a confidence level of 75% with an unknown standard deviation of the population) and the mean values of test series.
- The load/displacement curves.

##### 6.7.2 Dimensional stability of external cladding element

The mean, characteristic or tabulated value shall be indicated in the ETA.

##### 6.7.3 Immersion in water

The following shall be indicated in the ETA:

- The 5%-fractile values (for a confidence level of 75% with an unknown standard deviation of the population) and the mean values of test series.
- The load/displacement curves.

##### 6.7.4 Freeze-thaw

The cladding element shall be freeze-thaw resistant in accordance with the relevant EN or ISO standard.

The following shall be indicated in the ETA:

- The 5%-fractile values (for a confidence level of 75% with an unknown standard deviation of the population) and the mean values of test series.
- The load/displacement curves.
- The number of freeze-thaw cycles

#### 6.7.5 Chemical and biological attack

If necessary, the performance deterioration caused by chemical and biological attack shall be declared.

The Approval Body will establish if any deterioration will prevent the proper functioning of the kit under the serviceability loads.

#### 6.7.6 Corrosion

If necessary, the performance deterioration caused by corrosion shall be declared.

The Approval Body will establish if any deterioration will prevent the proper functioning of the kit under the serviceability loads.

The steel or aluminium grade has to be defined as a function of the field of application (e.g. marine atmosphere or industrial atmosphere).

In particularly aggressive atmosphere with extreme chemical pollution (e.g. desulphurization plants, chloride atmosphere), however, special measures of corrosion protection shall be foreseen.

#### 6.7.7 UV radiation

If appropriate, the performance deterioration caused by UV radiation shall be declared.

The Approval Body will establish if any deterioration will prevent the proper functioning of the kit under the serviceability loads.

The appraisal shall also take into account any determined safety factors.

## **7 ASSUMPTIONS AND RECOMMENDATIONS UNDER WHICH THE FITNESS FOR USE OF THE PRODUCT IS ASSESSED**

This chapter sets out the assumptions and recommendations for design, installation and execution, packaging, transport and storage, use, maintenance and repair under which the assessment of the fitness for use according to the ETAG can be made (only when necessary and in so far as they have a bearing on the assessment or on the products).

The wall, on which the kit is applied, shall ensure airtightness.

The wall shall be designed with due consideration to passive safety to prevent unnecessary injuries being inflicted on a person who accidentally falls against it.

### **7.1 DESIGN OF THE WORKS**

The works including the details (connection, joint, etc ...) shall be designed in order to avoid driving rain penetration beyond the kit or interstitial condensation.

It shall be possible to attach fixtures (down pipes, etc) into the substrate without damaging the integrity of the kit to a degree likely to reduce the overall performance.

It shall be checked that the fixing devices allow relative movements (temperature, humidity) between the cladding elements and the subframe, without damage.

The subframe shall be defined (distance between fixings, brackets,...) according to the type of cladding.

The design of the works (wall upgraded with the kit) shall be established on the hygrothermal point of view in order to determine the susceptibility of interstitial condensation.

Vermin and insects shall be prevented from entering the draining and/or ventilation openings.

### **7.2 EXECUTION OF THE WORKS**

The works shall be executed by trained installers.

The ETA and the supporting documents shall include a detailed description of the installation of the kit specifying the required procedures, the sequence and timing of operations and the method of fixing (machinery, equipment and tools). Particular operations, methods of fixings etc. shall be indicated in the ETA.

#### **7.2.1 Execution of the kit**

The cladding kit is positioned with continuous or discontinuous vertical and/or horizontal joints.

The execution of the kit should be limited to facades between movement joints.

The installation of the kit shall be realised in accordance with the manufacturer's specifications and drawings prepared for that purpose and using the specified tools. The cladding elements shall be installed without restraint.

The subframe shall have a flatness suitable for the cladding elements and their fixings.

The subframe protection against the climate shall be suited to the atmosphere.

For family B, the fitness of the special anchor for an intended use can only be assumed if the following conditions of installation are indicated in the ETA:

- The undercut holes on the back side of the cladding element shall be prepared in a way equivalent to factory conditions.
- In the event that drilling is aborted, a new drilling shall be made at a minimum distance away of twice the depth of the aborted drill hole
- Drilling of undercut holes shall be carried out in the presence of a responsible qualified person
- Installation is carried out by appropriately qualified personnel under the supervision of the person responsible for technical matters on site.
- Use of special anchors only as supplied by the manufacturer without exchanging the components.
- Installation in accordance with the manufacturer's specifications and drawings prepared for that purpose and using the specified tools.
- All installation data shall be shown clearly on the packaging and/or an enclosed instruction sheet, preferably using illustrations. The minimum data required are:
  - Drilling process and drill bit
  - Material of façade panel and its main physical and mechanical characteristics
  - Thickness of façade panel
  - Thickness of fixture
  - Installation process including cleaning of drill hole
  - Torque moment
  - Control dimension and measuring device

## 7.2.2 Maintenance and repair of the works

It is assumed that, for the kit to fully preserve its performance, the cladding shall be subject to normal maintenance.

Maintenance includes:

- Repairs to localised damaged areas due to accidents,
- The application of various products or paints, possibly after washing or ad hoc preparation.

Necessary repairs shall be affected rapidly.

It is important to be able to carry out maintenance as far as possible using readily available products and equipment, without affecting the appearance.

The cladding replacement manual shall be supplied by the manufacturer.

Comment: Care shall be taken to use products which are compatible with the kit.

## Section three: ATTESTATION OF CONFORMITY

### 8 EVALUATION AND ATTESTATION OF CONFORMITY AND CE MARKING

#### 8.1 System of attestation of conformity

According to the decision 2003/640/EC of the European Commission, the systems of attestation of conformity given in Table 6 and Table 7 apply.

**Table 6 – System of attestation of conformity applicable to cladding kit**

Product(s)	Intended use(s)	Level(s) or class(es)	Attestation of conformity system(s)
<b>Kits for exterior wall claddings</b>	external finishes of walls	-	<b>2+</b>
System 2+: See Directive 89/106/EEC Annex III.2.(ii), first possibility including certification of factory production control by an approved body on the basis of initial inspection of factory and of factory production control as well as of continuous surveillance, assessment and approval of the factory production control.			

**Table 7 – Choice of the system of attestation of conformity applicable to cladding kit with respect to reaction to fire**

Product(s)	Intended use(s)	Level(s) or class(es) <i>(reaction to fire)</i>	Attestation of conformity system(s)
<b>Kits for exterior wall claddings</b>	for uses subject to regulations on reaction to fire	A1*, A2*, B*, C*	<b>1</b>
		----- A1**, A2**, B**, C**, D, E	----- <b>3</b>
		----- (A1 to E)***, F	----- <b>4</b>
System 1: See Directive 89/106/EEC Annex III.2.(i), without audit-testing of samples System 3: See Directive 89/106/EEC Annex III.2.(ii), Second possibility System 4: See Directive 89/106/EEC Annex III.2.(ii), Third possibility * Products/ materials for which a clearly identifiable stage in the production process results in an improvement of the reaction to fire classification (e.g. an addition of fire retardants or a limiting of organic material) ** Products/ materials not covered by footnote (*). *** Products/ materials that do not require to be tested for reaction to fire (e.g. Products/materials of classes A1 according to Commission Decision 96/603/EC, as amended).			

The systems of attestation of conformity referred to above are defined as follows:

System 1: Certification of the conformity of the product by a notified certification body on the basis of:

a) Tasks for the manufacturer

- Factory production control,
- Possible further testing of samples taken at the factory by the manufacturer in accordance with a prescribed test plan.

b) Tasks for the notified body

- Initial type-testing of the product,
- Initial inspection of the factory and of factory production control,
- Continuous surveillance, assessment and approval of factory production control.

System 2+: Declaration of conformity of the product by the manufacturer on the basis of:

a) Tasks for the manufacturer

- Initial type-testing of the product,
- Factory production control,
- Testing of samples taken at the factory in accordance with a prescribed test plan.

b) Tasks for the notified body

Certification of factory production control on the basis of:

- Initial inspection of the factory and of factory production control,
- Continuous surveillance, assessment and approval of factory production control.

The tasks defined in 8.2 will vary depending on how the kit is produced. For example, the need to perform Initial Type Testing may be lower if the kit producer buys in components of known performance (especially if these components are also CE marked). In this same situation, the FPC needs of the kit producer will also be lower than if he manufactures one or more of the components himself. This difference shall be taken into account by the Approval Body in developing the ETA.

## 8.2 Tasks and responsibilities of the manufacturer and notified bodies

### 8.2.1 TASKS FOR THE MANUFACTURER

#### 8.2.1.1 Factory production control (All Systems of A/C)

The manufacturer shall exercise permanent internal control of production. All the elements, requirements and provisions adopted by the manufacturer shall be documented in a systematic manner in the form of written policies and procedures. This production control system shall ensure that the product is in conformity with the European Technical Approval (ETA).

Manufacturers having an FPC system which complies with EN ISO 9001 and which addresses the requirements of an ETA are recognized as satisfying the FPC requirements of the Directive.

A factory production control plan shall indicate the properties that shall be controlled and minimum frequencies of control.

### 8.2.1.2 Testing of samples taken at the factory – Prescribed Test Plan (system 1)

Both large and small companies produce the various components of the kits and there is a wide variation in the volume and in the production processes. Therefore a control plan can only be set up on a case by case basis. These tasks shall be specified in a control plan, in documentation which accompanies the ETA as to type, extent and frequency of testing and control.

### 8.2.1.3 Declaration of Conformity (for all AoC systems)

When all the criteria of the Conformity Attestation are satisfied the manufacturer shall make a Declaration of Conformity.

The EC declaration of conformity shall contain in particular:

- Name and address of the manufacturer or his agent established in the EU,
- Description of the product (type, identification, use, etc...),
- Provisions to which the product conforms (i.e. reference to the ETA based on this ETA-Guideline),
- Particular conditions applicable to the use of the product (i.e. reference to the ETA based on this ETA-Guideline),
- Name and address of the approved body,
- Name of, and position held by, the person empowered to sign the declaration on behalf of the manufacturer or of his authorised representative,

The declaration of conformity shall be presented in the language or languages accepted in the Member State in which the product is to be used.

## 8.2.2 TASKS OF THE MANUFACTURER OR THE NOTIFIED BODY: INITIAL TYPE TESTING

Approval tests will have been conducted by the approval body or under its responsibility (which may include a proportion conducted by an indicated laboratory or by the manufacturer, witnessed by the approval body) in accordance with chapter 5 of this ETAG. The approval body will have assessed the results of these tests in accordance with chapter 6 of this ETAG, as part of the ETA issuing procedure.

These tests shall be used for the purposes of Initial Type Testing<sup>(1)</sup>.

For system 1, this work shall be validated by the Approved Body for Certificate of Conformity purposes.

---

<sup>(1)</sup> In this respect Approval Bodies shall be able to have open arrangements with relevant Approved Bodies to avoid duplication, respecting each others responsibilities.



For system 2+, this work shall be taken over by the manufacturer for Declaration of Conformity purposes.

## 8.2.3 TASKS FOR THE NOTIFIED BODY

### 8.2.3.1 Assessment of the factory production control - initial inspection and continuous surveillance

Assessment of the factory production control is the responsibility of the approved inspection body.

An assessment shall be carried out of each production unit to demonstrate that the factory production control is in conformity with the ETA and any subsidiary information. This assessment shall be based on an initial inspection of the factory and of the factory production control.

Subsequently continuous surveillance of factory production control is necessary to ensure continuing conformity with the ETA.

Continuous surveillance inspections shall be conducted at least twice a year.

These tasks shall be specified in a control plan, in documentation which accompanies the ETA as to type, extent and frequency of testing and control.

### 8.2.3.2 Certification

The approved body shall issue:

- Certification of Conformity of the product (for system 1)
- Certification of Factory Production Control (for system 2+)

The certificate shall contain in particular:

- Name and address (identification number) of the certification body,
- Name and address of the manufacturer or his agent established in the Community,
- Description of the product (type, identification, use, etc...),
- Provisions to which the product conforms,
- Particular conditions applicable to the use of the product,
- The certificate's number,
- Conditions and period of validity of the certificate, where applicable,
- Name of, and position held by, the person empowered to sign the certificate.

The certificate shall be presented in the language or languages accepted in the Member State in which the product is to be used.

## 8.3 DOCUMENTATION

The approval body issuing the ETA shall compile, using information supplied by the manufacturer, the information detailed below. The information given below together with the requirements given in EC Guidance Paper B will generally form the basis on which the factory production control (FPC) is assessed.

This information shall initially be prepared or collected by the approval body and shall be agreed with the manufacturer. The following gives guidance on the type of information required:

1) The ETA

See section 9 of this Guideline.

The nature of any additional (confidential) information shall be declared in the ETA.

2) Basic manufacturing process

The basic manufacturing process shall be described in sufficient detail to support the proposed FPC methods.

3) Product and materials specifications

These may include:

- Detailed drawings (including manufacturing tolerances),
- Incoming (raw) materials specifications and declarations,
- References to European and/or international standards, appropriate specifications or manufacturer's data sheets.

4) Control plan

The manufacturer and the approval body issuing the ETA shall agree a control plan. This shall be deposited with the approval body in documentation which accompanies the ETA. A prescribed test plan is necessary as current standards relating to quality management systems (Guidance Paper B, EN ISO 9001, etc), do not ensure that the product specification remains unchanged and they cannot address the technical validity of the type or frequency of checks/tests.

The validity of the type and frequency of checks/tests conducted during production and on the final product shall be considered. This will include the checks conducted during manufacture on properties that cannot be inspected at a later stage and checks on the final product.

The following tables suggest as an example of such control plan for the Approval Bodies and shall be detailed case by case.

- Cladding element

Characteristic	Frequency
Length and width	1 per batch or 1 per day
Thickness	
Squareness	
Flatness	
Mass per unit area or per unit	
Mechanical test in accordance with Annex C.	Dependent on the cladding element

- Cladding fixing :
  - Dimensions
  - Mechanical characteristics
- Testing of kit

Characteristic	Frequency
Mechanical test in accordance with the paragraph 5.4.2	Dependent on the kit
Reaction to fire And Indirect test (loss ignition, ...)	1 per 5 years  1 per 1000 units

The test method is to be defined in each test plan product by product

For family B with stone, on 5 samples per 2 000 m<sup>2</sup> of façade panels surface, the axial tension resistance shall be checked. The size of test specimen and the diameter of the supporting ring shall be the same as in the test series according to § 5.4.2.2.1 where failure mode changes from pull-out of the fixing element or cone failure to bending failure of the test specimen. The smallest single value determined in the tests shall be equal to at least the characteristic value (see § 6.4.2.2).

Where materials/components are not manufactured and tested by the supplier in accordance with agreed methods, then where appropriate they shall be subject to suitable checks/tests by the manufacturer before acceptance.

##### 5) Control plan (for system 1)

The manufacturer and the approval body issuing the ETA shall agree a control plan.

This has to be deposited with the approval body in documentation which accompanies the ETA.

The characteristic to be addressed as described in the mandate is reaction to fire. This control plan will be controlled by the approved body at least twice a year by analysis/measurement of the relevant characteristics for components of the unit from the following list:

- composition

- dimensions
- physical properties
- mechanical properties
- production

## 8.4 CE MARKING AND INFORMATION

According to council directive 93/68/EEC the CE marking consists of the letters "CE" followed by the identification number of the notified body (system 1 or 2+).

The ETA shall indicate the information to accompany the CE marking and the placement of CE marking and the accompanying information (on the kit/components itself/themselves, an attached label, the packaging, or the accompanying commercial documents).

The CE marking shall be accompanied by the following information:

- name or identifying mark of the producer and the manufacturing plant,
- last two digits of the year in which the marking was affixed,
- number of the EC certificate of conformity for the products (system 1) or number of the EC certificate of conformity for the FPC (system 2+)
- number of the ETA (valid as indications to identify the characteristics of the claddings, the installation conditions necessary to ensure the declared performance of the kit and the characteristics where the "no performance determined" approach is used)
- name of the product

Example of CE marking:

	Letters "CE"
Any Company Street 1, City, Country XX XXXX	Name or identifying mark of the producer and the manufacturing plant
ETA- ETAG 034 Reaction to fire: Euroclass No dangerous substances	Last two digits of the year in which the marking was affixed  Number of the EC certificate of conformity for the products (system 1) or number of the EC certificate of conformity for the FPC (system 2+)  Number of the ETA
ETAG 034 Reaction to fire: Euroclass No dangerous substances	

# Section four: ETA CONTENT

---

## 9 THE ETA CONTENT

### 9.1 THE ETA CONTENT

The period of validity of an ETA issued under this ETAG shall be 5 years.

#### 9.1.1 Model ETA

The format of the ETA shall be based on the Commission Decision of 1997-07-22, EC Journal L236 of 1997-08-27.

#### 9.1.2 Checklist for the issuing body

The technical part of the ETA shall contain the following information as applicable to the system (hence given with a reference to the relevant clause of this guideline) or – where relevant - indicate the "no performance determined option".

Information on the kit:

- Indication of the assumed working life (Section two, GENERAL NOTES d)
- Classification of the kit and/or components with respect to reaction to fire (Euroclass) (Clause 6.2.1, 6.2.2 and 6.2.3); Class F is used instead of NPD for reaction to fire,
- Indication of watertightness of joints (Clause 6.3.1)
- Indication of drainability (Clause 6.3.4)
- Statement on the content and/or release of the following substances (Clause 6.3.5); NPD is not used against dangerous substances not present in the kit:
  - used wood: yes, if applicable
  - biocide(s), if applied or "PT" (treated with wood preservatives) according to EN 13986
  - Flame retardant/fire retardant, if applied, and the statement "No polybromated diphenylether"
  - Formaldehyde, if applied: class E1 or E2
  - Pentachlorophenol, if applied (content in ppm or mg/kg)
  - man made mineral fibres, if applied: Declaration of the carcinogenic potential of the used fibres (declaration if method I or II was used)

- ceramic fibres, if applied: yes
- cadmium: the content of cadmium contained on plastics, paints, lacquers, varnishes, zinc or zinc coatings shall be given. If cadmium or a cadmium compound is used as a coating this shall be declared.
- Declaration of the resistance of the kit to wind load (Clause 6.4.1.1 and 6.4.1.2)
- Declaration of the mechanical resistance of the kit (Clause 6.4.2)
- Statement on acceptable resistance to horizontal point load (Clause 6.4.3)
- Statement on the most severe use application for impact resistance for which the kit has been assessed (use category I, II or III, including description) (Clause 6.4.4)
- Statement on acceptable resistance to hygrothermal cycles (Clause 6.4.6)
- Statement on acceptable resistance to pulsating load (Clause 6.7.1)
- Statement on acceptable resistance to dimensional variation (Clause 6.7.2)
- Statement on acceptable resistance to immersion in water (Clause 6.7.3)
- Statement on acceptable resistance to freeze-thaw cycles (Clause 6.7.4)
- Statement on acceptable resistance to chemical and biological attack (Clause 6.7.5)
- Statement on acceptable resistance to corrosion (Clause 6.7.6)
- Statement on acceptable resistance to UV radiation (Clause 6.7.7)

For each of the above listed items, the ETA shall either give an indication/classification/ statement/description or state that the verification/assessment of this item has not been carried out (no performance determined).

Information on the design:

The ETA shall include annotated drawings with the dimensions marked and drawn to an adequate scale for components of the kit such as cladding and mechanical fixings, as well as a series of annotated detailed drawings with the dimensions.

The ETA shall include a selection of annotated drawings, to an adequate scale, of sections of the kit chosen from the following examples:

- Implantation of cladding fixings
- horizontal and vertical sections of cladding joints,
- section of dividing joint in the cladding kit.

These drawings shall be accompanied in each case by a description of the particular installation details.

### 9.1.3 Note concerning dangerous substances

In section II 2 “characteristics of products and methods of verification” the ETA shall include the following note:

“In addition to the specific clauses relating to dangerous substances contained in this European Technical Approval, there may be other requirements applicable to the products falling within its scope (e.g. transposed European legislation and national laws, regulations and administrative provisions). In order to meet the provisions of the EU Construction Products Directive, these requirements need also to be complied with, when and where they apply.

#### 9.1.4 Identification

The ETA shall contain information and/or references allowing for, where there is a need e.g. attestation of Conformity [see Chapter 8 clause 8.2.3.2], market surveillance, complaints or accidents [all Systems of A/C]), to determine that the products on the market, or intended to be put on the market are in compliance with the approved product as described in the ETA.

When such information/references are of a confidential nature it/they shall exist on the ETA file managed by the Approval body and as necessary on the relevant file of any notified body involved.

These information/references shall also be of assistance in any renewal of the ETA.

The type, scale, range of information will be based on the identification clauses in Chapter 5 of the ETAG.

The ETA is issued for the cladding kit on the basis of agreed data/information, which identifies the kit that has been assessed and judged. Changes to the product/production process/kit, which could result in this deposited data/information being incorrect, shall be notified to the Approval Body, before the changes are introduced. The Approval Body will decide whether or not such changes affect the ETA and consequently the validity of the CE marking on the basis of the ETA and if so whether further assessment/alterations to the ETA, shall be necessary.

# Annex A: COMMON TERMINOLOGY AND ABBREVIATIONS

---

## **A.1 Works and products**

### **A.1.1 Construction works (and parts of works) (often simply referred to as "works") (ID 1.3.1)**

Everything that is constructed or results from construction operations and is fixed to the ground. (This covers both building and civil engineering works, and both structural and non-structural elements).

### **A.1.2 Construction products (often simply referred to as "products") (ID 1.3.2)**

Products which are produced for incorporation in a permanent manner in the works and placed as such on the market.

(The term includes materials, elements, components and prefabricated kits or installations).

### **A.1.3 Incorporation (of products in works) (ID 1.3.2)**

Incorporation of a product in a permanent manner in the works means that:

- its removal reduces the performance capabilities of the works, and
- that the dismantling or the replacement of the product are operations which involve construction activities.

### **A.1.4 Intended use (ID 1.3.4)**

Role(s) that the product is intended to play in the fulfilment of the essential requirements.

(N.B.: This definition covers only the intended use as far as relevant for the CPD).

### **A.1.5 Execution (ETAG-format)**

Used in this document to cover all types of incorporation techniques such as installation, assembling, incorporation, etc...

### **A.1.6 System (EOTA/TB guidance)**

System refers to an assembled system which is a kit after it has been installed in the works.

An "assembled system" may be made up only of the "kit" or it may comprise the "kit" assembled with one or more other products which may or may not themselves be construction products. In the wording of the CPD, "assembled system" is the equivalent of "works or part of the works".

An "assembled system" is not considered to be a construction product in the sense of the CPD because it is the result of the combination of components incorporated in the works and therefore exists only in the works and not on the market.

## **A.2 Performances**

### **A.2.1 Fitness for intended use (of products) (CPD 2.1)**

Means that the products have such characteristics that the works in which they are intended to be incorporated, assembled, applied or installed, can, if properly designed and built, satisfy the essential requirements.



### **A.2.2 Serviceability (of works)**

Ability of the works to fulfil their intended use and in particular the essential requirements relevant for this use.

The products shall be suitable for construction works which (as a whole and in their separate parts) are fit for their intended use, account being taken of economy, and in this connection satisfy the following essential requirements where the works are subject to regulations containing such requirements.

*Such requirements shall, subject to normal maintenance, be satisfied for an economically reasonable working life. The requirements generally concern actions which are foreseeable.*

### **A.2.3 Essential requirements (for works)**

Requirements applicable to works, which may influence the technical characteristics of a product, and are set out in objectives in the CPD, Annex I (CPD, art. 3.1).

### **A.2.4 Performance (of works, parts of works or products) (ID 1.3.7)**

The quantitative expression (value, grade, class or level) of the behaviour of the works, parts of works or of the products, for an action to which it is subject or which it generates under the intended service conditions (works or parts of works) or intended use conditions (products).

As far as practicable the characteristics of products, or groups of products, shall be described in measurable performance terms in the technical specifications and guidelines for ETA. Methods of calculation, measurement, testing (where possible), evaluation of site experience and verification, together with compliance criteria shall be given either in the relevant technical specifications or in references called up in such specifications.

### **A.2.5 Actions (on works or parts of the works) (ID 1.3.6)**

Service conditions of the works which may affect the compliance of the works with the essential requirements of the Directive and which are brought about by agents (mechanical, chemical, biological, thermal or electro-mechanical) acting on the works or parts of the works. Interactions between various products within works are considered as "actions".

### **A.2.6 Classes or levels (for essential requirements and for related product performances) (ID 1.2.1)**

A classification of product performance(s) expressed as a range of requirement levels of the works, determined in the ID's or according to the procedure provided for in art. 20.2 a of the CPD.

## **A.3 ETAG-Format**

### **A.3.1 Requirements (for works) (ETAG-format 4)**

Expression and application, in more detail and in terms applicable to the scope of the guideline, of the relevant requirements of the CPD given concrete form in the ID's and further specified in the mandate, for works or parts of the works, taking into account the durability and serviceability of the works.

### **A.3.2 Methods of verification (for products) (ETAG-format 5)**

Verification methods used to determine the performance of the products in relation to the requirements for the works (calculations, tests, engineering knowledge, evaluation of site experience, etc...).

These verification methods are related only to the assessment of, and for judging the fitness for use. Verification methods for particular designs of works are called here "project testing", for identification of products are called "identification testing", for surveillance of execution or executed works are called "surveillance testing", and for attestation of conformity are called "AC-testing".

#### **A.3.3 Specifications (for products) (ETAG-format 6)**

Transposition of the requirements into precise and measurable (as far as possible and proportional to the importance of the risk) or qualitative terms, related to the products and their intended use.

The satisfaction of the specifications is deemed to satisfy the fitness for use of the products concerned.

Specifications may also be formulated with regard to the verification of particular designs, for identification of products, for surveillance of execution or executed works and for attestation of conformity, when relevant.

#### **A.3.4 EOTA Technical reports**

EOTA Technical reports go in to detail expressing the common understanding of existing knowledge and experience of the EOTA bodies at that moment. Where knowledge and experience is developing, especially through approval work, these reports can be amended and supplemented. When this happens, the effect of the changes upon the ETAG will be determined by EOTA.

### **A.4 Working life**

#### **A.4.1 Working life (of works or parts of the works) (ID 1.3.5 [1])**

The period of time during which the performance will be maintained at a level compatible with the fulfilment of the essential requirements.

#### **A.4.2 Working life (of products)**

The period of time during which the performances of the product are maintained, under the corresponding service conditions, at a level compatible with the intended use conditions.

#### **A.4.3 Economically reasonable working life (ID 1.3.5 [2])**

Working life which takes into account all relevant aspects, such as costs of design, construction and use, costs arising from hindrance of use, risks and consequences of failure of the works during its working life and cost of insurance covering these risks, planned partial renewal, costs of inspections, maintenance, care and repair, costs of operation and administration, of disposal and environmental aspects.

#### **A.4.4 Maintenance (of works) (ID 1.3.3 [1])**

A set of preventive and other measures which are applied to the works in order to enable the works to fulfil all its functions during its working life. These measures include cleaning, servicing, repainting, repairing, replacing parts of the works where needed, etc...

#### **A.4.5 Normal maintenance (of works) (ID 1.3.3 [2])**

Maintenance, normally including inspections, which occurs at a time when the cost of the intervention which has to be made is not disproportionate to the value of the part of the work concerned, consequential costs (e.g. exploitation) being taken into account.

#### **A.4.6 Durability (of products)**

Ability of the product to contribute to the working life of the works by maintaining its performances, under the corresponding service conditions, at a level compatible with the fulfilment of the essential requirements by the works.

#### **A.5 Conformity**

##### **A.5.1 Evaluation of conformity (of products)**

Provisions and procedures as laid down in the CPD and fixed according to the directive, aiming to ensure that, with acceptable probability, the specified performance of the product is achieved by the ongoing production.

##### **A.5.2 Identification (of a product)**

Product characteristics and methods for their verification, allowing comparing a given product with the one that is described in the technical specification.

#### **A.6 Abbreviations**

##### **A.6.1 Abbreviations concerning the Construction products directive**

AC: Attestation of Conformity  
CEN: Comité Européen de Normalisation  
CPD: Construction Products Directive  
EC: European Commission  
EFTA: European Free Trade Association  
EN: European Standards  
ER: Essential Requirements  
EU : European Union  
FPC: Factory Production Control  
ID: Interpretative Documents of the CPD  
ISO: International Standardisation Organisation  
SCC: Standing Committee for Construction of the EC

##### **A.6.2 Abbreviations concerning approval**

EOTA: European Organisation for Technical Approvals  
ETA: European Technical Approval  
ETAG: European Technical Approval Guideline  
TB: EOTA-Technical Board  
UEAtc: Union Européenne pour l'Agrément technique dans la construction (European Union of Agreement)

##### **A.6.3 General abbreviations**

TC: Technical Committee  
WG: Working Group

# Annex B:

## REFERENCE DOCUMENTS

---

### *Reference documents*

EOTA Guidance Document 004	Guidance Document on the Provision of Data for Assessments Leading to ETA
EOTA Guidance Document 001	Determination of impact resistance of panels and panel assemblies
Commission Decision	02/545 Rev. 3
EC GP B (September 2002)	GUIDANCE PAPER B - THE DEFINITION OF FACTORY PRODUCTION CONTROL IN TECHNICAL SPECIFICATIONS FOR CONSTRUCTION PRODUCTS
EC GP C (September 2002)	<b>Guidance Paper C - The treatment of kits and systems under the construction products directive</b>
EC GP E (September 2002)	<b>Guidance Paper E - Levels and Classes in the Construction Products Directive</b>
EN ISO 9001 ( <b>November 2008</b> )	Quality management systems – Requirements
EN 1990 (April 2002)	Basis of structural design
EN 13830 (September 2003)	Curtain walling - Product standard
EN 14509 (November 2006)	Self-supporting double skin metal faced insulating panels - Factory made products - Specifications
ETAG 016 (NOVEMBER 2003)	GUIDELINE FOR EUROPEAN TECHNICAL APPROVAL of SELF-SUPPORTING COMPOSITE LIGHTWEIGHT PANELS
<a href="#">CEN/TR 14823 (2003)</a>	Durability of wood and wood-based products - Quantitative determination of pentachlorophenol in wood - Gas chromatographic method

### **Verification of reaction to fire**

EN 13501-1 (February 2007)	Fire classification of construction products and building elements – Part 1: Classification using test data from reaction to fire tests
EN 13823 (February 2002)	Reaction to fire tests for building products – Building products excluding floorings exposed to the thermal attack by a single burning item

EN 13238 (May 2001) Reaction to fire tests for building products - Conditioning procedures and general rules for selection of substrates

#### **Verification of permeability**

EN 12865 (March 2001) Hygrothermal performance of buildings – Determination of resistance to driving rain under pulsating air pressure – Part 1: External wall systems

#### **Verification of safety in use**

ISO 7892 (1988) Vertical building elements - Impact resistance test - Impact bodies and general test procedures

#### **Verification of durability**

ISO 846 (1997) Plastics – Determination of behaviour under the action of fungi and bacteria – Evaluation by visual examination or measurement of change in mass or physical properties

ISO 877-3 (2009) Plastics – Methods of exposure to direct weathering, to weathering using glass-filtered daylight, and to intensify weathering by daylight using Fresnel mirrors

EN ISO 877-1 (March 2011) Plastics – Methods of exposure to solar radiation - Part 1: General guidance

ISO 877-2 (March 2011) Plastics – Methods of exposure to solar radiation - Part 2: Direct weathering and exposure behind window glass

ISO 877-3 (March 2011) Plastics – Methods of exposure to solar radiation - Part 3: Intensified weathering using concentrated solar radiation  
EN ISO 4892-1 (September 2000) Plastics – Methods of exposure to laboratory light sources – Part 1: General guidance

EN ISO 4892-2 (February 2006) Plastics – Methods of exposure to laboratory light sources – Part 2: Xenon-arc sources

EN ISO 4892-3 (February 2006) Plastics – Methods of exposure to laboratory light sources – Part 3: Fluorescent UV lamps

ISO 4892-4 (September 2004) Plastics – Methods of exposure to laboratory light sources – Part 4: Open-flame carbon-arc lamps

EN 14147 (**November 2003**) Natural stone test methods – Determination of resistance to ageing by salt mist

#### **Natural stone**

EN 1936 (December 2006) Determination of the apparent density

EN 12371 (March 2010)	Determination of frost resistance
EN 12372 (December 2006)	Determination of modulus of elasticity in bending and of bending strength
EN 13364 (November 2001)	Natural stone test methods - Determination of the breaking load at dowel hole
EN 14581 (December 2004)	Determination of linear thermal coefficient
EN 14147 ( <b>November 2003</b> )	Natural stone test methods - Determination of resistance to ageing by salt mist

### **Terra cotta**

EN 538 (May 1994)	Determination of modulus of rupture and breaking strength
EN 539-2 (June 2006)	Determination of frost resistance

### **Fibre-cement**

EN 12467 (December 2004)	Fibre-cement flat sheets – Products specifications and test methods
--------------------------	---

### **Glass-fibre reinforced cement**

EN 1170-4 (November 1997)	Test method for glass-fibre reinforced cement – Part 4: Measuring bending strength – Simplified flexural tensile test method
EN 1170-6 (November 1997)	Test method for glass-fibre reinforced cement – Part 6: Determination of the absorption of water by immersion and determination of the dry density
EN 1170-7 (November 1997)	Test method for glass-fibre reinforced cement – Part 7: Measurement of extremes of dimensional variations due to moisture content

### **Plastics**

EN 13245-2 (September 2008)	Unplasticized polyvinylchloride (PVC-U) profiles for building applications – Part 2: Profiles for external and internal wall and ceiling finishes
EN 477 ( <b>May 1995</b> )	Unplasticized polyvinylchloride (PVC-U) profiles for the fabrication of windows and doors – Determination of the resistance to impact of main profiles by falling mass
EN ISO 178 (December 2010)	Plastics – Determination of flexural properties
EN ISO 179-1 (June 2010)	Plastics – Determination of Charpy impact test – Part 1: Determination of Charpy impact strength

EN ISO 179-2 (June 1999)      Plastics – Determination of Charpy impact test – Part 2: Instrumented impact test

ISO 1183 (1987)                Plastics – Methods for determining the density and relative density of non-cellular plastics

### **Laminates**

EN 438-2 (January 2005)      High-pressure decorative laminates (HPL) – Sheets based on thermosetting resins – Part 2: Determination of properties

EN 438-7 (January 2005)      High-pressure decorative laminates (HPL) – Sheets based on thermosetting resins – Part 7: Compact laminate and HPL composite panels for internal and external wall and ceiling finishes

### **Wood based product**

EN 310 (February 1993)      Wood based panels – Determination of modulus of elasticity in bending and of bending strength

EN 318 (March 2002)        Wood based panels – Determination of dimensional changes associated with changes in relative humidity

EN 321 (November 2001)     Wood based panels – Determination of moisture resistance under cyclic test conditions

EN 323 (February 1993)      Wood based panels – Determination of density

EN 335-1 (August 2006)      Durability of wood and wood based products – Definition of hazard classes of biological attack – Part 1: General

EN 335-2 (August 2006)      Durability of wood and wood based products – Definition of hazard classes of biological attack – Part 2: Application to solid wood

EN 335-3 (**July 1995**)       Durability of wood and wood based products – Definition of hazard classes of biological attack – Part 3: Application to wood based panels

EN 350-2 (**May 1994**)       Durability of wood and wood based products – Natural durability of solid wood – Part 2: Guide to natural durability and treatability of selected wood species of importance in Europe

EN 351-1 (July 2007)        Durability of wood and wood based products – Preservative-treated solid wood – Part 1: Classification of preservative penetration and retention

EN 460 (July 2007)        Durability of wood and wood based products – Natural durability of solid wood – Guide to the durability requirements for wood to be used in hazard classes

EN 599-1 (2009)	Durability of wood and wood based products – Performance of preventive wood preservative as determined by biological tests – Part 1: Specification according to hazard class
EN 599-2 (1995)	Durability of wood and wood based products – Performance of preventive wood preservative as determined by biological tests – Part 2: Classification and labelling
EN 13986 (October 2004)	Wood-based panels for use in construction – Characteristics, evaluation of conformity and marking
EN 927-2 (April 2006)	Paints and varnishes - Coating materials and coating systems for exterior wood - Part 2: Performance specification

### **Steel, Aluminium and aluminium alloys**

EN 1670 (March 2007)	Building hardware - Corrosion resistance - Requirements and test methods
EN 10020 (March 2000)	Definition and classification of grades of steel
EN 10088-1 (June 2005)	Stainless steels – Part 1: List of stainless steels
EN 10088-2 (June 2005)	Stainless steels – Part 2: Technical delivery conditions for sheet/plate and strips for general purposes
EN 10169 (October 2010)	Continuously organic coated (coil coated) steel flat products - Technical delivery conditions
EN 10346 (March 2009)	Continuously hot-dip coated steel flat products - Technical delivery conditions
EN 13523-10 (March 2010)	Coil coated metals - Test methods - Part 10: Resistance to fluorescent UV light and water condensation
EN 485-2 (October 2008)	Aluminium and aluminium alloys – Sheet, strip and plate – Part 2: Mechanical properties
EN 573 -3 (April 2009)	Aluminium and aluminium alloys – Chemical composition and form of wrought product – Part 3: Chemical composition
EN 755-1 (March 2008)	Aluminium and aluminium alloys – Extruded rod/bar, tube and profiles - Part 1: Technical conditions for inspection and delivery
EN 755-2 (March 2008)	Aluminium and aluminium alloys – Extruded rod/bar, tube and profiles - Part 2: Mechanical properties
EN 1396 (January 2007)	Aluminium and aluminium alloys – Coil coated sheet and strip for general applications – Specification
EN 1999-1-1 (May 2007)	Eurocode 9: Design of aluminium structures - Part 1-1: General rules - general rules and rules for buildings



### **Polyester panels**

EN ISO 10352 (December 2010) Fibre-reinforced plastics – Moulding compounds and prepregs – Determination of mass per unit area

### **Ceramics**

EN ISO 10545-3 (**July 1997**) Ceramic tiles – Part 3: Determination of water absorption, apparent porosity, apparent relative density and bulk density

EN ISO 10545-4 (**July 1997**) Ceramic tiles – Part 4: Determination of modulus of rupture and breaking strength

EN ISO 10545-6 (**July 1997**) Ceramic tiles – Part 3: Determination of hardness

EN ISO 10545-8 (**July 1997**) Ceramic tiles – Part 8: Determination of linear thermal expansion

EN ISO 10545-10 (**July 1997**) Ceramic tiles – Part 10: Determination of moisture expansion

EN ISO 10545-12 (**July 1997**) Ceramic tiles – Part 12: Determination of frost resistance

### **Fixing**

EN ISO 898-1 (April 2009) Mechanical properties of fasteners made of carbon steel and alloy steel – Part 1: Bolts, screws and studs.

EN ISO 3506-1 (November 2009) Mechanical properties of corrosion-resistant stainless-steel fasteners – Part 1: Bolts, screws and studs.

### **Insulation**

EN 13162 (**November 2008**) Thermal insulation products for buildings - Factory made mineral wool (MW) products – Specification

EN 13163 (**November 2008**) Thermal insulation products for buildings - Factory made products of expanded polystyrene (EPS) – Specification

EN 13164 (**November 2008**) Thermal insulation products for buildings - Factory made products of extruded polystyrene foam (XPS) – Specification

EN 13165 (**November 2008**) Thermal insulation products for buildings - Factory made rigid polyurethane foam (PUR) products – Specification

EN 13166 (**November 2008**) Thermal insulation products for buildings - Factory made products of phenolic foam (PF) – Specification

These documents are referred to in the ETAG and are subject to the specific conditions mentioned therein.

# **Annex C:**

## **METHODS RELATED TO THE IDENTIFICATION OF THE PHYSICAL AND MECHANICAL CHARACTERISTICS OF CLADDING ELEMENT**

---

### C.1. Specific mass or density

Determination of the specific mass or density on twelve specimens in accordance with the Standard°:

- for natural stone : EN 1936
- for fibre cement flat sheet : EN 12467
- for composite cement glass : EN 1170-6
- for steel : EN 10346
- for aluminium : EN 1396
- for polyester compound moulded panel : EN ISO 10352
- for PVC : ISO 1183-Method A
- for wood based panels : EN 323
- for ceramics : EN ISO 10545-3
- EN or ISO standard otherwise internal procedure for other materials

### C.2 Bending stress, Modulus of elasticity or Modulus of rupture

Determination of the bending stress, Modulus of elasticity or Modulus of rupture on twelve specimens in accordance with the Standard°:

- for natural stone : EN 12372
- for fibre cement flat sheet : EN 12467
- for composite cement glass : EN 1170-4
- for steel : EN 10346
- for aluminium : EN 485-2
- for PVC, the polyester compound moulded panel, the laminates panels : EN ISO 178
- for wood based panels : EN 310
- for ceramics : EN ISO 10545-4
- for terra cotta : EN 538
- EN or ISO standard otherwise internal procedure for other materials

Note: If relevant, the bending strength of cladding element can be tested after conditioning to high and low temperature.

### C.3 Hardness

Determination of the hardness on three specimens in accordance with the Standard°:

- for panel of mortar polyester : EN ISO 179
- for laminates panels : EN 438-2
- for PVC : EN 477
- for ceramics : EN ISO 10545-6
- EN or ISO standard otherwise internal procedure for other materials

### C.4 Freeze-thaw sensitivity

Determination of the non freeze-thaw sensitivity in accordance with the following Standard°:

- for natural stone : EN 12371
- for terra cotta : EN 539-2
- for fibre cement flat sheet : EN 12467
- for PVC : EN 477
- for ceramics : EN ISO 10545-12
- EN or ISO standard otherwise internal procedure for other materials

### C.5 Water absorption

Determination of the water absorption in accordance with the following Standard°:

- for fibre cement flat sheet : EN 12467
- for glass fibre reinforced cement: EN 1170-6
- for ceramics : EN ISO 10545-3
- EN or ISO standard otherwise internal procedure for other materials

# Annex D: GENERAL TEST RESULTS STATISTICAL INTERPRETATION

---

$$F_{u,5} = F_{\text{mean}} - k_n \cdot S$$

$$\Delta F_{\text{mean}} = F_{\text{mean},c} / F_{\text{mean},n}$$

Where

- $F_{u,5}$  = the characteristic breaking force giving 75 % confidence that 95 % of the test results will be higher than this value
- $F_{\text{mean}}$  = the mean breaking force, either under tension or shear
- $F_{\text{mean},n}$  = the mean breaking force, either under tension or shear in the initial state
- $F_{\text{mean},c}$  = the mean breaking force, either under tension or shear after conditioning or ageing
- $k_n$  = the eccentricity of 5 % with 75 % confidence (see Table 8)
- $S$  = the standard deviation of series under consideration

**Table 8 – The variable  $k_n$  as a function of the number of test pieces (see EN 1990 Eurocode: Basis of structural design, Table D1,  $V_{x,\text{unknown}}$ )**

Number of pieces	3	4	5	6	7	8	10	20	30	$\infty$
Variable $k_n$	3,37	2,63	2,33	2,18	2,10	2,00	1,92	1,76	1,73	1,64

# **Annex E: MOUNTING AND FIXING PROVISIONS FOR THE SBI TEST**

---

The reaction to fire testing shall be given for the entire kit, in simulating its end-use conditions.

The testing standard EN 13823 Reaction to fire tests for building products – Building products excluding floorings exposed to the thermal attack by a single burning item gives a general description of the arrangement of the test specimen for SBI test, applicable to classes A2, B, C and D (in some cases also to A1).

This Annex describes specific provisions for cladding kits.

## **1. General information**

As a function of the intended use of the kit, the specimen shall be installed on a substrate in accordance with standard EN 13238:

- Calcium silicate or fibre-cement board simulates a wall made of masonry or concrete,
- Non FR particle board simulates a wall made of timber frame,
- Steel sheet simulates a wall made of metal frame.

The frame is made from non fire-retardant treated timber, aluminium or steel.

All components which form part of the kit (e.g. breather membranes and cavity barriers) shall be included in a representative fashion in the test specimen.

An air space is always provided under cladding in accordance with the manufacturer's instructions (minimum of 20 mm). The bottom and top edges of the specimen shall also remain opened.

If mineral wool insulation layer is planned in end-use situation of the kit, a 50 mm thick insulation product made of mineral wool according to EN 13162, with a density of 30 to 70 kg/m<sup>3</sup>, shall be installed between frame and substrate.

For other insulation materials, different conditions can be used for testing (e.g. maximum and/or minimum thicknesses, maximum and/or minimum density, unless proven otherwise).

The cladding elements are fixed to the frame. The cladding kit shall be installed with fixing devices density defined by the manufacturer as specified in the ETA.

When the kit tested presents a horizontal joint, it shall be tested with a horizontal joint in the long wing at a height of 500 mm from the bottom edge of the specimen and when the kit tested presents a vertical joint, it shall be tested with a vertical joint in the long wing at a distance of 200 mm from the corner line, in accordance with the following Figure E 1. In the

areas A, B, C, D and E, it is possible to have other vertical and/or horizontal joints between cladding element, if their size is not big enough.

In the internal vertical angle, no profile shall be used and the cladding elements create a vertical close joint.

Note: Asymmetrically composed cladding products are tested free-hanging arrangement in such a way that the rear of the product is exposed to the flame (see paragraph 5.2.2).

**Figure E 1 - Example of installation**

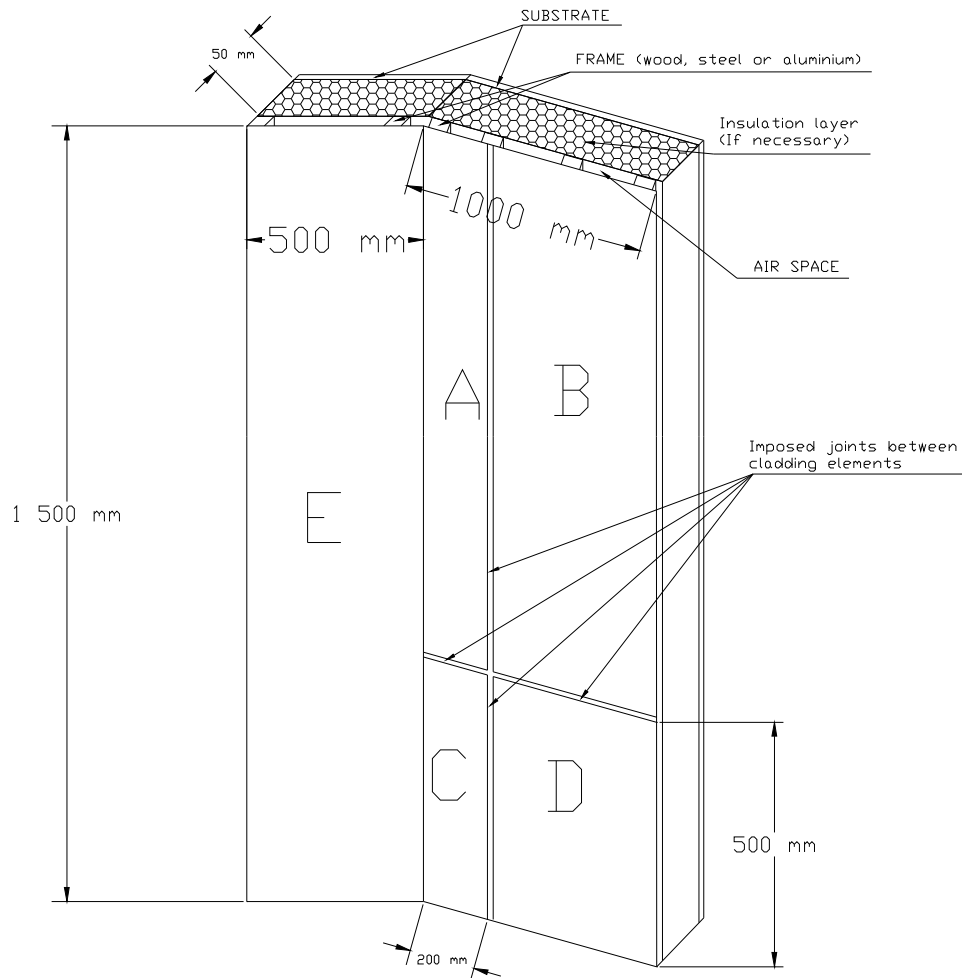

The two wings are perpendicular.

## 2. Specific information

The different families of cladding kits are tested in a limited number of configurations to cover the influence of the following parameters, for instance, lower and high thickness of the cladding element, type of fixings, maximum density of fixings according to the following paragraphs.

## 2.1 Family A, B

The panels can be cut to size as shown in Figure E 2.

The products are fixed to the frame by through fixing (family A) or hidden fixing (family B).

**Figure E 2 - Example of installation for family A or B**

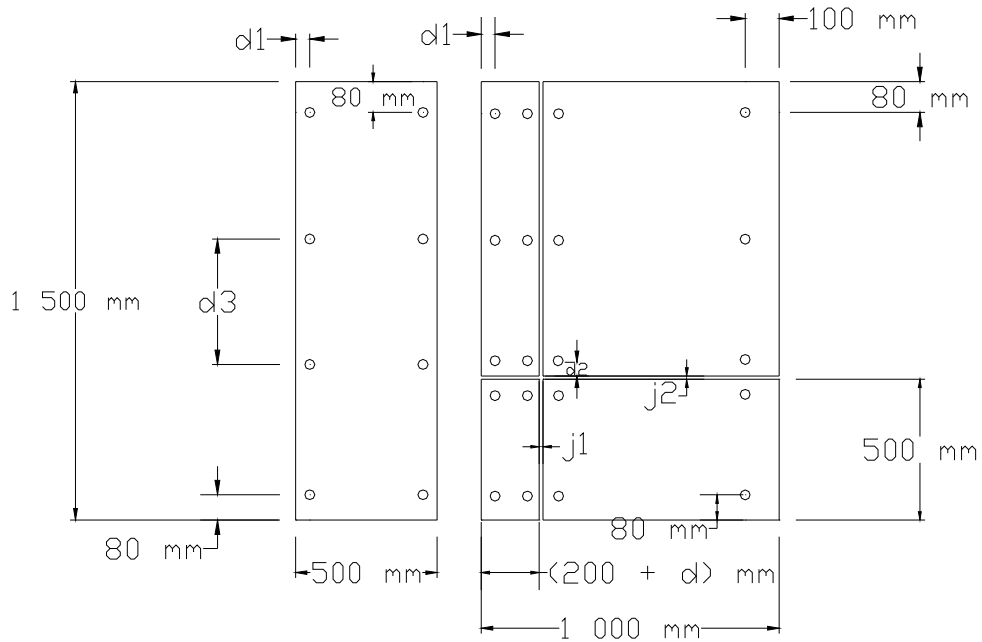

## 2.2 Family C or D

The cladding elements can be cut to size as shown in Figure E 3.

**Figure E 3 - Example of installation for family C or D**

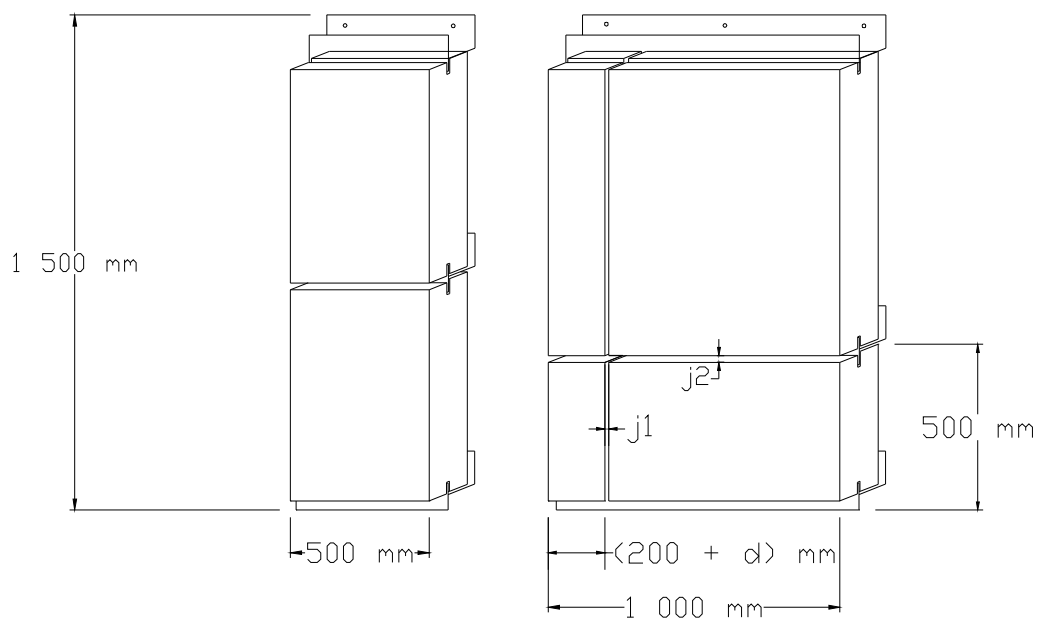

### 2.3 Family E

The cladding elements can be cut to size as shown in Figure E 4.

**Figure E 4 - Example of installation for family E**

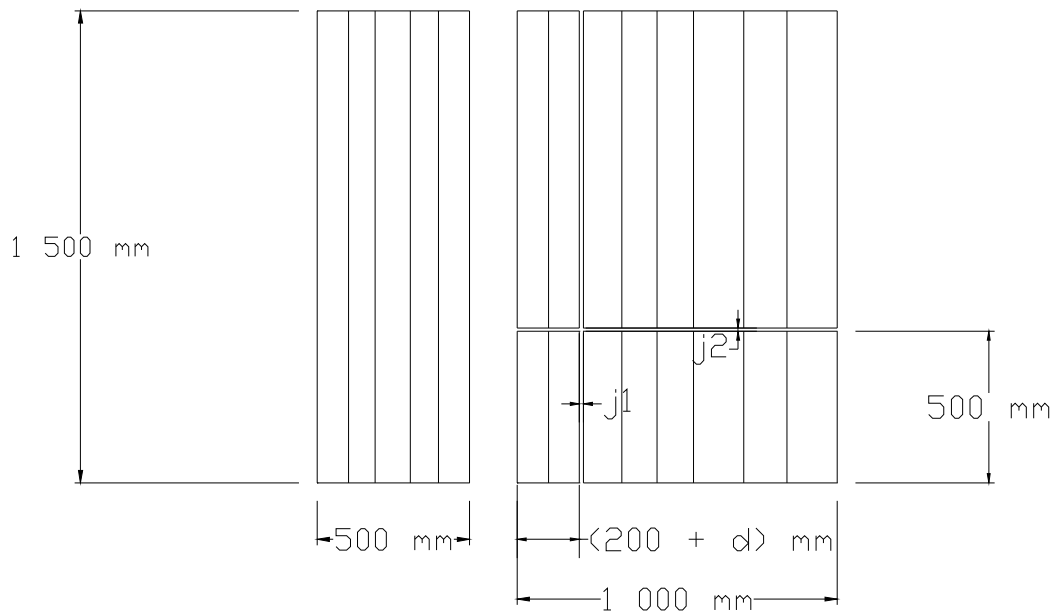

### 2.4 Family F

The cladding elements can be cut to size as shown in Figure E 5.

**Figure E 5 - Example of installation for family F**

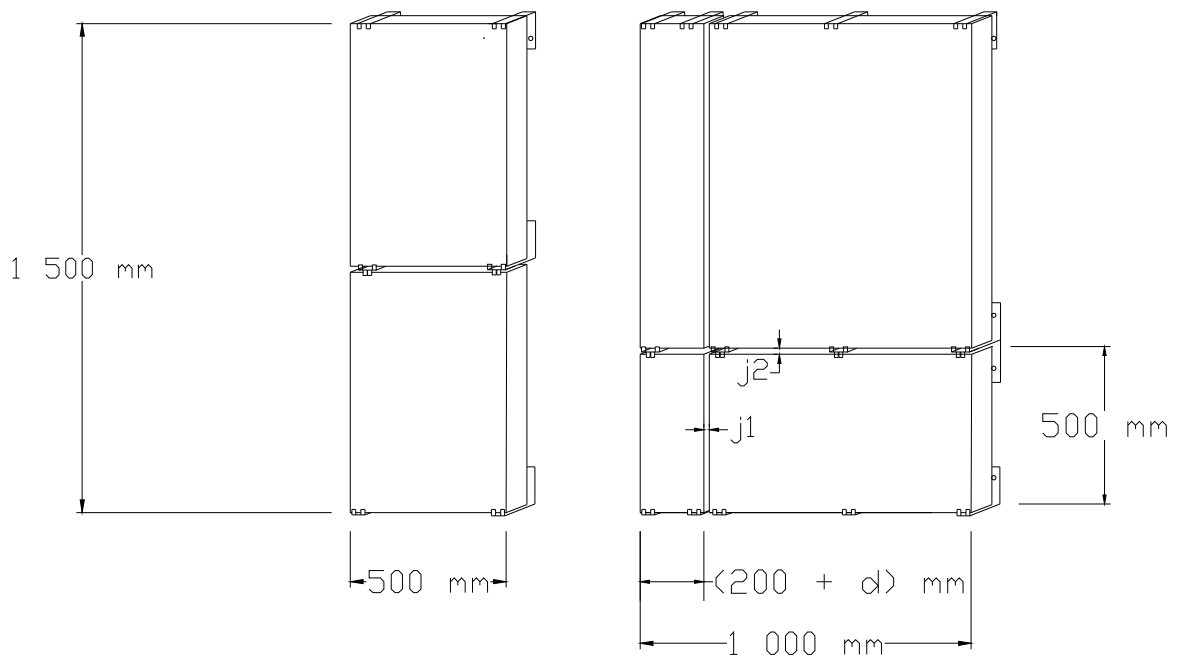



## 2.5 Family G

The cladding elements can be cut to size as shown in Figure E 6.

**Figure E 6 - Example of installation for family G**

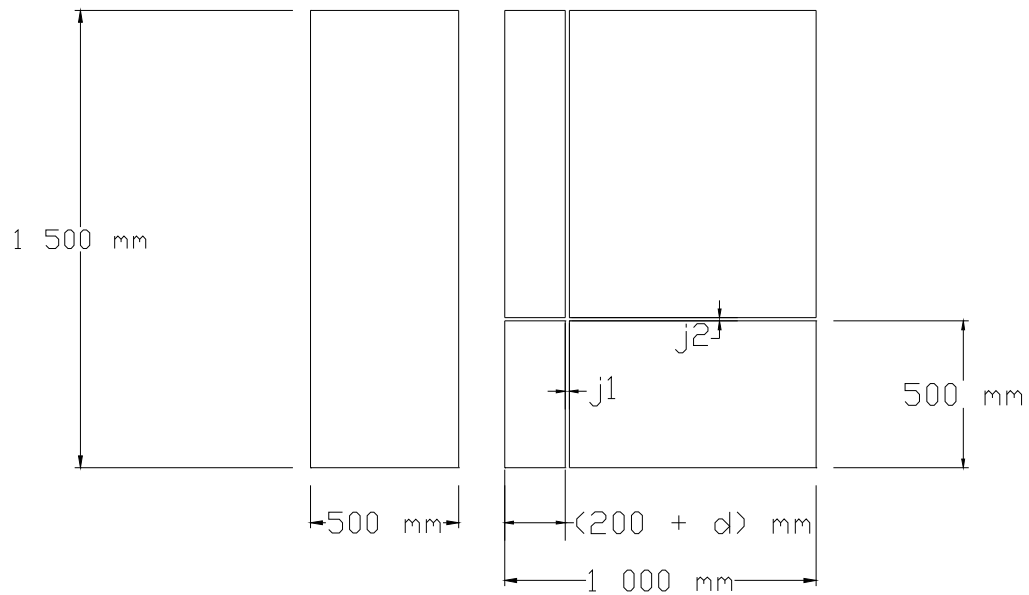

## 2.6 Family H

The cladding elements can be fixed as shown in Figure E 7.

**Figure E 7 – Example of installation for family H**

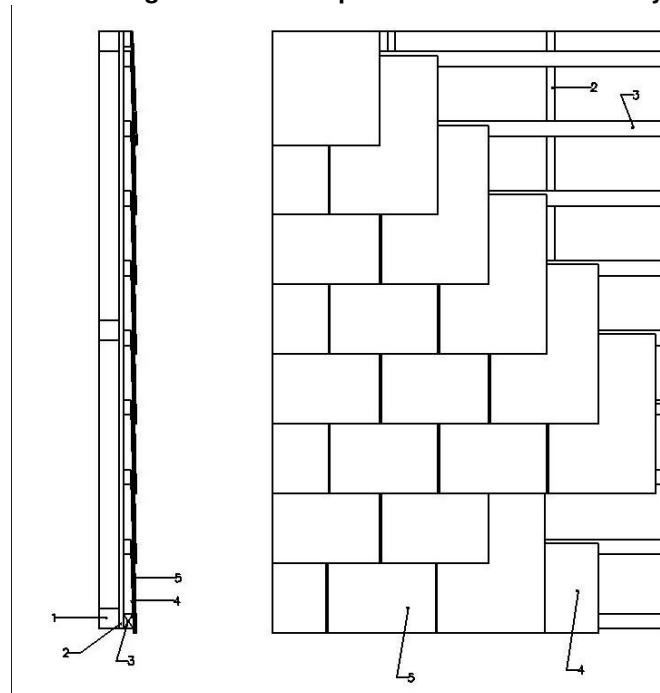

- 1 Supporting frame
- 2 Timber batten ( $20 \pm 1$ ) mm
- 3 Timber counter batten ( $19 \pm 1$ ) mm x ( $38 \pm 1$ ) mm
- 4 Under eave slates
- 5 Slate for testing

### 3. Extension of results

The test result (classification) shall remain valid, without test:

- For greater dimensions (height and width) of cladding elements
- For other higher density of fixing device
- For the same type of panel (for family A to G) used in applications with open vertical joint  $\leq j_1$  (tested value) and open horizontal joint  $\leq j_2$  (tested value), up to 15 mm (see figure E2 to E6).
- For all other greater thickness of mineral wool insulation layer with the same density and the same or better reaction to fire classification, if the panels have been tested with mineral wool insulation layer
- For other higher thickness of air space

The test result of a test with mineral wool insulation shall be valid, without test, for the same type of panel used without insulation, if the substrate chosen according to EN 13238 is made of panel with Euro-class A1 or A2 (e.g. fibres-cement panel).

The results of reaction to fire tests, where a combustible insulation material was used as substrate, are also valid for end-use applications of the tested product without insulation on solid mineral substrates of class A1 or A2-s1,d0 like masonry or concrete.

The test result of a test with non fire-treated timber frame shall be valid, without test, for the same type of panel used with aluminium or steel frame.

The test result of a test with screws shall be valid, without test, for the same type of panel fixed by rivets made of the same material as the screws (steel screws for steel rivets and aluminium screws for aluminium rivets) and vice versa.

The test result of the lowest and highest thickness of the cladding element shall be valid, without test, for all the thickness in between.

The result from a test with an open horizontal joint shall be valid, without test, for the same type of panel used in applications with horizontal joints closed by steel or aluminium profiles.