



# ENVIRONMENTAL PRODUCT DECLARATION

in accordance with ISO 14025:2010  
and EN 15804:2012

**ATLAS ETICS  
EXTERNAL THERMAL INSULATION COMPOSITE SYSTEMS  
WITH SILICATE RENDERS**



 <sup>®</sup> quality in construction  
**Building Research Institute**



ITB is the member of  The European platform for EPD program operators





## ENVIRONMENTAL PRODUCT DECLARATION

### ATLAS ETICS EXTERNAL THERMAL INSULATION COMPOSITE SYSTEMS WITH SILICATE RENDERS

Issuance date: 10.03.2014

Validity date: 10.03.2019

#### EPD PROGRAM OPERATOR

BUILDING RESEARCH INSTITUTE

00-611 Warsaw, ul. Filtrowa 1

[www.itb.pl](http://www.itb.pl)

#### MANUFACTURER:

ATLAS spółka z o.o.

91-222 Łódź, ul. Św. Teresy 105,

Poland

[atlas@atlas.com.pl](mailto:atlas@atlas.com.pl) [www.atlas.com.pl](http://www.atlas.com.pl)

#### Manufacturing sites information

Zakład Produkcyjny PIOTRKÓW TRYBUNALSKI,

97-300 Piotrków Trybunalski, ul. Wronia 61/63,

Poland

Zakład Produkcyjny BYDGOSZCZ,

85-758 Bydgoszcz, ul. Przemysłowa 32,,

Poland

Zakład Produkcyjny DĄBROWA GÓRNICZA,

41-306 Dąbrowa Górnicza, ul. Roździeńskiego 2,

Poland

Zakład Produkcyjny SUWAŁKI,

16-400 Suwałki, Dubowo II nr 33,

Poland

Wytwórnia Klejów i Zapraw Budowlanych S.A.

95-100 Zgierz, ul. Szczawińska 52A,

Poland

# ENVIRONMENTAL PRODUCT DECLARATION

**ATLAS ETICS**  
**EXTERNAL THERMAL INSULATION COMPOSITE SYSTEMS**  
**WITH SILICATE RENDERS**  
 in accordance with ISO 14025:2010 and EN 15804:2012



## 1. BASIC INFORMATION

This declaration is the type III Environmental Product Declaration (EPD) based on EN 15804 and verified according to ISO 14025. It contains information about the impact of declared construction materials on environment and their aspects verified by the independent Advisory Board according to ISO 14025. Basically, a comparison or evaluation of EPD data is possible only if all the compared data were created according to EN 15804 (see point 5.3 of the norm) and the building context.

Issuance date: 10.03.2014  
 Validation date: 01.03.2014  
 Validity date: 10.03.2019  
 Declared durability: 50 years

## 2. LIFE CYCLE ASSESSMENT (LCA)

### Declared unit

The declaration refers to 1 kg of dry mortar.

### System limits

The life cycle analysis of the examined products covers A1-A3 modules (Cradle to Gate) in accordance with EN 15804:2012. Its include production, including raw materials extraction and energy provision up to the finished, packed product at the factory gate. Processes whose total contribution to the final result, according to mass looked at, is less than 0.5 % was ignored.

### Data collection period

The data for manufacture of the examined products refer to the year 2012. The life cycle assessments were prepared for Poland as reference area.

### Data quality

The values determined to calculate the LCA originate from verified Atlas inventory data.

### Assumptions and estimates

The impacts of the representative ATLAS products for each ETICS layer were aggregated using weighted average. The weighted average method was used according to the percentage of each product in ETISC based on the relation to whole production quantity. Impacts for each product and factory were inventoried and calculated separately.

### Note

Factory-prefabricated boards made of expanded polystyrene (EPS), mesh glass fibre and anchors are not produced by ATLAS. The impacts of those products were included from databases shown below.

### Databases

The data for the processes come from the following databases: Ecoinvent, EMPA, Ullmann's, Plastic-Europe, ITB-Data, SPC.

## 3. PRODUCT INFORMATION

ATLAS ETICS is a trade name for External Thermal Insulation Composite System, which comprises insulation board (bonded and mechanically fixed) with reinforced undercoat,

and decorative finishes as described in Technical Approval AT-15-9090/2014 (Domestic Approval). The system is complete and equipped with a vast selection of adhesives, base coats, renders and decorative coats of various colours. The system provides variety of solutions depending on requirements of the investors, building designers and construction workers. ATLAS ETICS also offers a wide range of solutions for all building types, from detached houses to multi-storey developments (< 25 m high). It is fully certified and the exact specification is tailored to meet the requirements of each project, whether residential or commercial, in compliance with all current building regulations in Poland.

## 4. PRODUCT DESCRIPTION

ATLAS ETICS is External Thermal Insulation Composite System in accordance with Polish national requirements described in ZUAT-15/V.03/2010. Kits to perform the thermal insulation of external walls using EPS boards as a thermal insulating material and a thinned facade finishes.

The insulation system is a kit of materials to be used in the proper order of layers and with the use of appropriate technology.

Components are shown below in Table 1.

**Table 1.** ATLAS ETICS components

Intended scope	Trade name
Adhesives for bonding the insulation product	ATLAS HOTER S ATLAS STOPTER K-10
Insulation product *)	Factory-prefabricated, uncoated panels made of expanded polystyrene (EPS) according to EN 13163:2013
Reinforced layer	Adhesives for base coat ATLAS HOTER U ATLAS STOPTER K-20 ATLAS STOPTER K-50
	Glass fibre meshes *) AKE SSA-1363-SM 0.5
Key coats	ATLAS CERPLAST ATLAS SILKAT ASX ATLAS SILKON ANX
Finishing coats	ATLAS CERMIT mineral ATLAS CERMIT acryl ATLAS DEKO M/DEKO DIM ATLAS SILKAT ATLAS SILKON TYNK AKRYLOWY ATLAS TYNK SILIKONOWY ATLAS TYNK SILIKONOWO-SILIKATOWY ATLAS TYNK AKRYLOWO-SILIKONOWY ATLAS
Primers	ATLAS ARKOL SX ATLAS ARKOL NX
Decorative coats	ATLAS ARKOL E ATLAS ARKOL S ATLAS ARKOL N ATLAS FASTEL NOVA
Ancillary materials *)	Anchors, special fittings (e.g. base profiles, corner profiles ...)

\*) products from suppliers, ATLAS does not produce these items.

# ENVIRONMENTAL PRODUCT DECLARATION

**ATLAS ETICS**  
**EXTERNAL THERMAL INSULATION COMPOSITE SYSTEMS**  
**WITH SILICATE RENDERS**  
 in accordance with ISO 14025:2010 and EN 15804:2012



Layers' arrangement in the ATLAS ETICS system is shown on Figure 1

Figure 1. ATLAS ETICS scheme

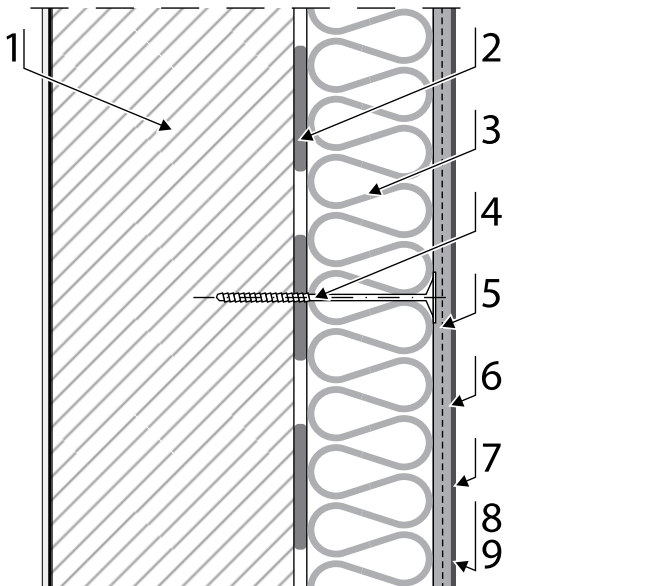

1. Wall structure (substrate)
2. Adhesive (basic fixing)
3. Thermal insulation (EPS)
4. Anchor (if necessary, additional fixing)
5. Reinforced layer (base coat with glass fibre mesh embedded)
6. Key coating (if necessary)
7. Finishing coat (renders)
8. Primers (optional)
9. Decorative coats (optional)

The main objectives of the ATLAS ETICS system are given below:

- providing external walls with appropriate thermal insulation (U value),
- reducing the costs for heating (also for cooling)
- reducing CO<sub>2</sub> and environmental protection
- improving thermal comfort for residents
- increase in durability of external walls by ensuring better protection from weather conditions
- "new look" for buildings walls.

The layers have precisely defined their technical and performance functions:

- adhesives are used for bonding the insulation product to the wall substrate and ensure stability of insulation
- the suitable thickness of EPS plates assures required thermal isolation,
- base coat applied directly onto the insulation product; the reinforcement is embedded into it and provides most of the mechanical properties of the rendering, glass fibre mesh in the base coat to improve its mechanical strength
- key coat - very thin coat which may be applied to the base coat and is intended to act as a preparation for the application of the finishing coat.
- finishing coat - coat which contributes to the protection against weathering and can provide a decorative finish;
- decorative coat - optional coat which generally provides the aesthetic finishing

The Technical Approval AT-15-9090/2014 covers a very wide range of products to perform every single layer of insulation system, for example 5 kinds of adhesives for bonding EPS boards, 3 kinds of adhesive to make the base coat, 3 kinds of key coats, 9 kinds of finishing coats (renders) and 5 kinds of façade paints. Also the thickness of the polystyrene foam boards, used during the work, can vary in every single case. Accordingly, environmental characteristics (LCA) for ATLAS ETICS are presented in a few cases, depending on:

- kind of finishing coat (mineral, acrylic, silicate, silicone or mixed (silicone-silicate and acrylic-silicone), and
- thickness of EPS boards for reference cases 10 cm, 12 cm, 15 cm or 20 cm.

Table 2. Overview of possible solutions – adhesives and reinforcement materials in combination with the relevant system finishing and decorative coats

Insulation fixing - basic	ATLAS HOTER S or ATLAS STOPTER K-10
Insulation product	EPS boards, density 20 kg/m <sup>3</sup>
Insulation fixing – additional	4 pieces per 1 m <sup>2</sup>
Base coat	ATLAS HOTER U or ATLAS STOPTER K-20 or ATLAS STOPTER K-50
Glass fibre meshes	AKE or SSA-1363-SM 0.5
Key coat	ATLAS SILKAT ASX
Finishing coat	ATLAS SILKAT
Primers *)	ATLAS ARKOL SX or ATLAS ARKOL NX
Decorative *)	ATLAS ARKOL E or ATLAS ARKOL S or ATLAS ARKOL N or ATLAS FASTEL NOVA

\*) decorative coats (with primers) are not necessary

Table 3. An overview of average consumption particular products

ATLAS HOTER S or ATLAS STOPTER K-10	4.0 – 5.0 kg/m <sup>2</sup>
EPS boards, density 20 kg/m <sup>3</sup>	1 m <sup>2</sup> /1 m <sup>2</sup>
Anchors	4 pieces /1 m <sup>2</sup>
ATLAS HOTER U or ATLAS STOPTER K-20 or ATLAS STOPTER K-50	3.0 – 3.5 kg/m <sup>2</sup>
AKE or SSA-1363-SM 0.5	1.1 m <sup>2</sup> /1m <sup>2</sup>
ATLAS SILKAT ASX	0.3 kg/m <sup>2</sup>
ATLAS SILKAT	2.5 – 3.0 kg/m <sup>2</sup>
ATLAS ARKOL SX or ATLAS ARKOL NX	0.05 – 0.20 kg/m <sup>2</sup>
ATLAS ARKOL E or ATLAS ARKOL S or ATLAS ARKOL N or ATLAS FASTEL NOVA	0.125 – 0.280 kg/m <sup>2</sup>

# ENVIRONMENTAL PRODUCT DECLARATION

**ATLAS ETICS**  
**EXTERNAL THERMAL INSULATION COMPOSITE SYSTEMS**  
**WITH SILICATE RENDERS**  
 in accordance with ISO 14025:2010 and EN 15804:2012



**Table 4.** List of ATLAS ETICS varieties in the cases of different thickness EPS boards

Short description	EPS thickness	Environmental characteristic
ETICS with silicate render	10 cm	See Table 10
	12 cm	See Table 11
	15 cm	See Table 12
	20 cm	See Table 13

## 5. PRODUCT MANUFACTURE

### Raw materials and energy

**Table 5.** Raw materials used to produce ATLAS ETICS with silicate renders

No	Name of semi-finished product or raw material	total used in production [Mg]	used on product [%/kg]	used on product [kg/m <sup>2</sup> ]
<b>Adhesives</b>				
1	raw materials	20567.8	95.450	3.1274
2	additives	372.4	1.730	0.065
3	rest components (each < 0.5 %)	153.6	0.710	0.0281
4	pallet	341.9	1.590	0.0423
5	PE foil st	44.5	0.210	0.0136
6	PE foil	3.3	0.020	0.0008
7	multilayer paper bag	65.0	0.300	0.0072
<b>Silicate renders</b>				
1	raw materials	263.0	62.470	2.063
2	additives	84.7	20.119	0.663
3	rest components (each < 0.5 %)	11.8	2.803	0.092
4	pallet	21.9	5.202	0.172
5	PE foil st	1.1	0.261	0.008
6	PE foil	0.1	0.024	0.001
7	carton spacer	0.6	0.143	0.005
8	bucket	14.4	3.420	0.113
9	water	23.4	5.558	0.183
<b>Façade paints and primers</b>				
1	raw materials	537.700	40.076	0.1829
2	additives	389.000	28.993	0.1056
3	rest components (each < 0,5 %)	16.5	1.230	0.0073
4	pallet	42.6	3.175	0.0106
5	PE foil st	4.5	0.335	0.0003
6	PE foil	18.2	1.356	0.0003
7	carton spacer	2.4	0.1789	0.0035
8	bucket	36.2	2.698	0.0292
9	water	294.6	21.957	0.0914

The figures below show the working process during the production of dry mixes (Figure 2), ready-to-use renders (Figure 3) and paints (Figure 4). The raw materials are stored in the production factory in silos, big bags, or sacks accordingly. According to the applicable formulation, they are dosed and intensely mixed. Next, products are filled into containers (or packed into paper bags – dry mixes) and send to quality control. Then, they are temporarily stored, or delivered directly as ready-to-use products.

**Figure 2.** Production process – dry mixes (scheme)

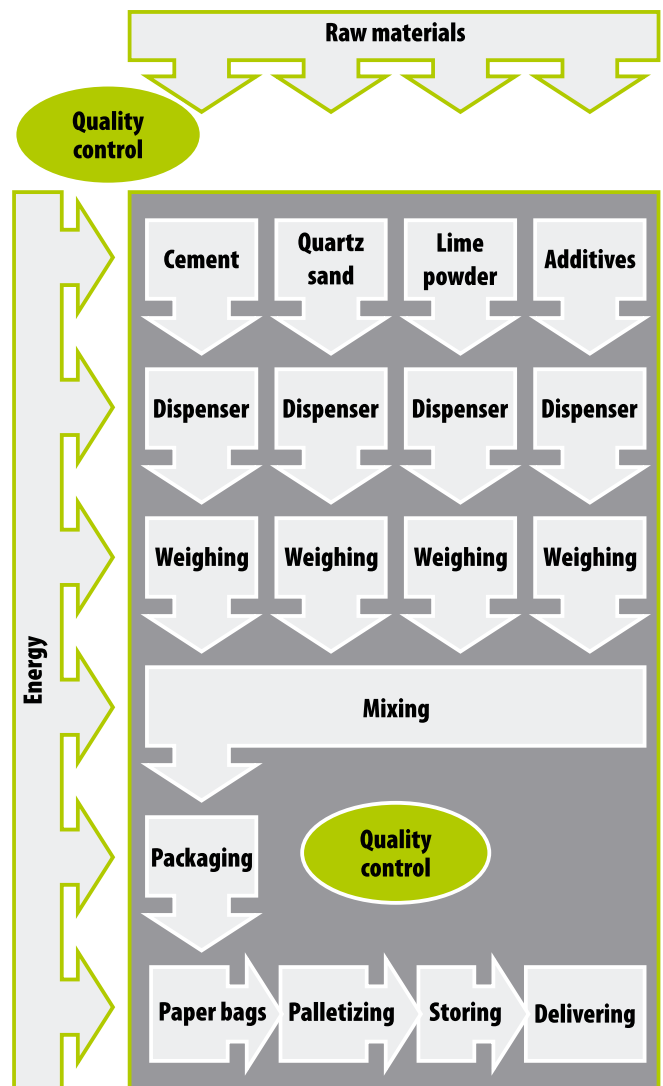

# ENVIRONMENTAL PRODUCT DECLARATION

**ATLAS ETICS**  
**EXTERNAL THERMAL INSULATION COMPOSITE SYSTEMS**  
**WITH SILICATE RENDERS**  
 in accordance with ISO 14025:2010 and EN 15804:2012



Figure 3. Production process – ready-to-use renders (scheme)

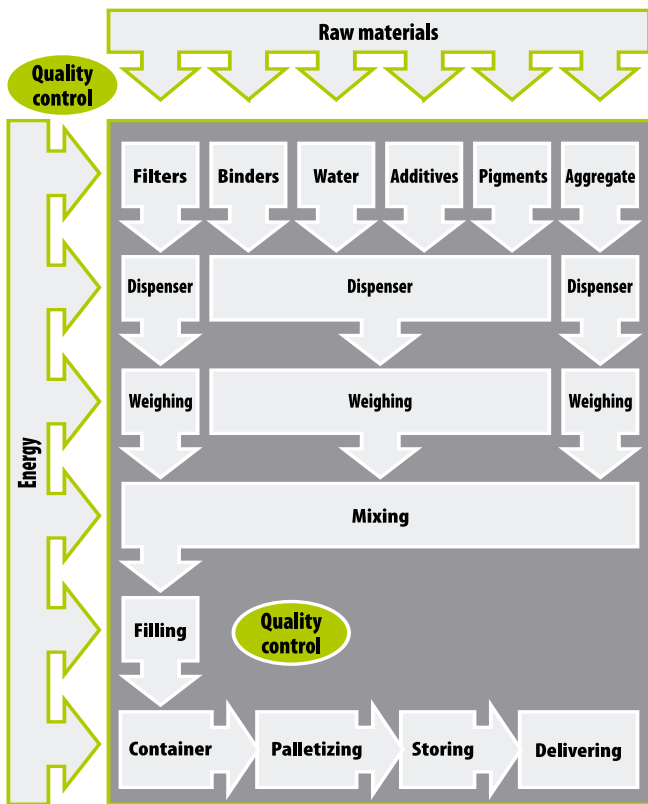
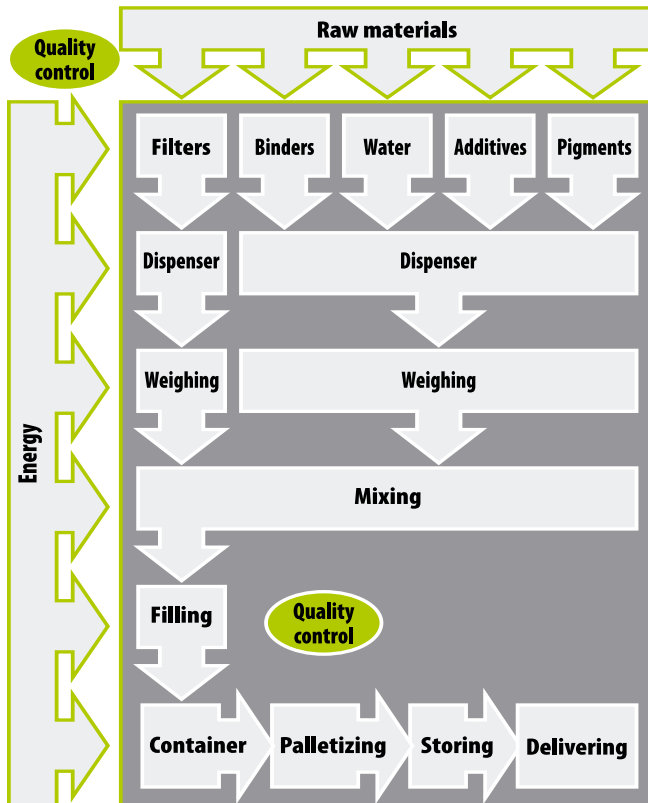

Figure 4. Production process – paints and primers (scheme)



## 6. PRODUCT APPLICATION

The thermal insulation technology, used in fixing thermal insulation, is made of foamed polystyrene boards (EPS) to the substrate and preparation of a reinforced layer, a render coating and, a paint coating (optionally). The system can be applied both on new, or existing external surfaces of vertical building walls (already plastered, or not) made of masonry, or adhered materials, such as bricks and blocks (ceramic, lime-sand, stone, cellular concrete), or of concrete (poured at the construction site, or in the form of prefabricated elements). To perform each of the layers, according to the need, one of different construction products listed in Table 1 and then in Table 2 can be used.

### Occupational safety and environmental protection

Occupational safety and environmental protection are described in Material Safety Data Sheets (MSDS) for each product.

### Note

Specific information on application and other actions with these products are described in detail in the Technical Data Sheet available on the producer website [www.atlas.com.pl](http://www.atlas.com.pl).

## 7. EMISSIONS (LCI) AND THEIR IMPACT ON THE ENVIRONMENT

The following chapter show the life cycle inventory analysis of the adhesives with regard to primary energy needs, water needs, emissions into air and waste.

Table 6. Primary energy consumption for A3 module

Energy resource	Unit	used on product [unit/Mg]	used on product [unit/m <sup>2</sup> ]
electricity	kWh	62.54	0.700
black coal	Mg	—	—
lignite coal	Mg	—	—
coke	Mg	—	—
ON (only inside fabric)	litrs	1.28	0.014
benzin 95	litrs	—	—
oil	litrs	0.45	0.005
natural gas	m <sup>3</sup>	15.31	0.171
LPG	litrs	—	—

Table 7. Emissions into air generated during production stage A3

Table 8. Emissions into water generated during production

Air emission	Unit	used on product [kg/Mg]	used on product [kg/m <sup>2</sup> ]
Dust	kg	0.23	2.60E-03
CO	kg	0.02	1.69E-04
CO <sub>2</sub>	kg	12.60	1.41E-01
NO <sub>2</sub>	kg	0.026	2.95E-04
SO <sub>2</sub>	kg	0.022	2.50E-04
NH <sub>3</sub>	kg	3.28E-06	3.67E-08
HCl	kg	0.0001	6.92E-07
CH <sub>4</sub>	kg	0.0002	1.96E-06
NM VOC	kg	0.0002	1.69E-06
N <sub>2</sub> O	kg	0.0001	8.47E-07

# ENVIRONMENTAL PRODUCT DECLARATION

**ATLAS ETICS**  
**EXTERNAL THERMAL INSULATION COMPOSITE SYSTEMS**  
**WITH SILICATE RENDERS**  
in accordance with ISO 14025:2010 and EN 15804:2012



stage A3

Water and sewage	Unit	Total amount
Water	m <sup>3</sup>	40632
<b>Industrial Sewage</b>	m <sup>3</sup>	27
BOD	mg/l	200
COD	mg/l	350
pH	°-	8
Suspended matter	mg/l	100
<b>Municipal Sewage</b>	m <sup>3</sup>	16773
BOD	mg/l	28
COD	mg/l	77
pH	°-	7.7
Suspended matter	mg/l	32
Nitrogen amonian	mg/l	0.64
Phosphorans	mg/l	0.9

**Table 9.** Waste generated in the phase of product manufacturing A3

Waste code	Unit	total in production [Mg]	used on product [kg/Mg]	used on product [kg/m <sup>2</sup> ]
<b>Adhesives</b>				
150101	Mg	113.384	0.1845	0.0007
150102	Mg	76.513	0.1245	0.00047
101382	Mg	1892.8	3.0801	0.0117
150103	Mg	54.02	0.0879	0.00033
150105	Mg	80.14	0.1304	0.00050
161002	Mg	32.66	0.0531	0.0002
170107	Mg	321.764	0.5236	0.00199
150202	Mg	1.808	0.0029	0.00001
170405	Mg	10.812	0.0176	0.00007
160304	Mg	37.567	0.0611	0.00023
150106	Mg	27.24	0.0443	0.00017
<b>Mix render</b>				
150101	Mg	91.755	0.4895	0.00162
150102	Mg	53.753	0.2868	0.00095
101382	Mg	1149.9	6.1346	0.02024
130208	Mg	0.8	0.0043	1.41E-05
150110	Mg	0.109	0.0006	1.92E-06
150202	Mg	1.678	0.0090	2.95E-05
150203	Mg	2	0.0107	3.52E-05
160107	Mg	0.12	0.0006	2.11E-06
170405	Mg	6.272	0.0335	1.10E-04
80112	Mg	1.361	0.0073	2.40E-05
130307	Mg	0.083	0.0004	1.46E-06
150105	Mg	61.36	0.3274	1.08E-03
160216	Mg	0.79	0.0042	1.39E-05
160304	Mg	37.567	0.2004	6.61E-04
170107	Mg	319.824	1.7062	0.00563
150103	Mg	90.36	0.4821	0.00159
<b>Façade paints and primers</b>				
150101	Mg	20.24	0.1785	7.14E-05
150102	Mg	11.102	0.0979	3.92E-05
10408	Mg	99.96	0.8818	3.53E-04
080120	Mg	0.66	0.0058	2.33E-06
101382	Mg	1316.6	11.6	4.65E-03
150110	Mg	0.037	0.0003	1.31E-07
150202	Mg	0.09	0.0008	3.18E-07
160213	Mg	0.143	0.0013	5.05E-07
160214	Mg	0.071	0.0006	2.51E-07
160216	Mg	0.032	0.0003	1.13E-07
160601	Mg	0.35	0.0031	1.24E-06
170203	Mg	9.96	0.0879	3.51E-05



# ENVIRONMENTAL PRODUCT DECLARATION

**ATLAS ETICS**  
**EXTERNAL THERMAL INSULATION COMPOSITE SYSTEMS**  
**WITH SILICATE RENDERS**  
 in accordance with ISO 14025:2010 and EN 15804:2012



## 9. ENVIRONMENTAL CHARACTERISTICS (LCA)

The results of the LCA with the indicators as per EPD requirement are given in the following tables for product manufacture (A1, A2, A3 modules).

**Table 10.** Environmental characteristic for 1 m<sup>2</sup> of ETICS (silicate render), 10cm EPS

Environmental assessment information (MND – Module not declared, MD – Module Declared)																
Product stage			Construction process		Use stage							End of life			Benefits and loads beyond the system boundary	
Raw material supply	Transport	Manufacturing	Transport to construction site	Construction-installation process	Use	Maintenance	Repair	Replacement	Refurbishment	Operational energy use	Operational water use	Deconstruction demolition	Transport	Waste processing	Disposal	Reuse-recovery-recycling potential
A1	A2	A3	A4	A5	B1	B2	B3	B4	B5	B6	B7	C1	C2	C3	C4	D
MD	MD	MD	MND	MND	MND	MND	MND	MND	MND	MND	MND	MND	MND	MND	MND	MND

Environmental impacts: 1 m <sup>2</sup>					
Indicator	Unit	A1	A2	A3	A1-A3
Global warming potential	[kg CO <sub>2</sub> eq.]	11.5	0.1	0.3	11.9
Depletion potential of the stratospheric ozone layer	[kg CFC 11 eq.]	7.37E-07	5.66E-07	3.34E-09	1.31E-06
Acidification potential of soil and water	[kg SO <sub>2</sub> eq.]	0.0367	0.0006	0.0005	0.0378
Eutrophication potential	[kg (PO <sub>4</sub> ) <sup>3-</sup> eq.]	0.0035	0.0007	0.0001	0.0043
Formation potential of tropospheric ozone	[kg Ethene eq.]	0.0025	0.00	0.0021	0.0047
Abiotic depletion potential (ADP-elements) for non-fossil resources	[kg Sb eq.]	0.13	0.00	0.00	0.13
Abiotic depletion potential (ADP-fossil fuels) for fossil resources	[MJ]	193.3	1.1	4.4	198.8

Environmental aspects on resource use: 1 m <sup>2</sup>					
Indicator	Unit	A1	A2	A3	A1-A3
Use of renewable primary energy excluding renewable primary energy resources used as raw materials	[MJ]	INA	INA	INA	INA
Use of renewable primary energy resources used as raw materials	[MJ]	INA	INA	INA	INA
Total use of renewable primary energy resources (primary energy and primary energy resources used as raw materials)	[MJ]	1.05	0.00	0.34	1.38
Use of non-renewable primary energy excluding non-renewable primary energy resources used as raw materials	[MJ]	INA	INA	INA	INA
Use of non-renewable primary energy resources used as raw materials	[MJ]	INA	INA	INA	INA
Total use of non-renewable primary energy resources (primary energy and primary energy resources used as raw materials)	[MJ]	214.12	1.13	4.78	220.04
Use of secondary material	[kg]	0.69	0.00	0.00	0.69
Use of renewable secondary fuels	[MJ]	1.81	0.00	0.00	1.81
Use of non-renewable secondary fuels	[MJ]	2.49	0.00	0.00	2.49
Net use of fresh water	[dm <sup>3</sup> ]	3.86	0.01	0.75	4.62

Other environmental information describing waste categories: 1 m <sup>2</sup>					
Indicator	Unit	A1	A2	A3	A1-A3
Hazardous waste disposed	[kg]	0.002	0	0	0.002
Non-hazardous waste disposed	[kg]	0.97	0.005	0.1	1.075
Radioactive waste disposed	[kg]	0	0	0	0
Components for re-use	[kg]	0	0	0.054	0.054
Materials for recycling	[kg]	0.09	0.001	0.01	0.101
Materials for energy recovery	[kg]	0	0	0	0
Exported energy	[MJ]	0	0	0	0

# ENVIRONMENTAL PRODUCT DECLARATION

**ATLAS ETICS**  
**EXTERNAL THERMAL INSULATION COMPOSITE SYSTEMS**  
**WITH SILICATE RENDERS**  
 in accordance with ISO 14025:2010 and EN 15804:2012



Table 11. Environmental characteristic for 1 m<sup>2</sup> of ETICS (silicate render), 12cm EPS

Environmental assessment information (MND – Module not declared, MD – Module Declared)																
Product stage			Construction process		Use stage							End of life			Benefits and loads beyond the system boundary	
Raw material supply	Transport	Manufacturing	Transport to construction site	Construction-installation process	Use	Maintenance	Repair	Replacement	Refurbishment	Operational energy use	Operational water use	Deconstruction demolition	Transport	Waste processing	Disposal	Reuse-recovery-recycling potential
A1	A2	A3	A4	A5	B1	B2	B3	B4	B5	B6	B7	C1	C2	C3	C4	D
MD	MD	MD	MND	MND	MND	MND	MND	MND	MND	MND	MND	MND	MND	MND	MND	MND

Environmental impacts: 1 m <sup>2</sup>					
Indicator	Unit	A1	A2	A3	A1-A3
Global warming potential	[kg CO <sub>2</sub> eq.]	12.9	0.1	0.3	13.2
Depletion potential of the stratospheric ozone layer	[kg CFC 11 eq.]	7.53E-07	5.66E-07	3.34E-09	1.32E-06
Acidification potential of soil and water	[kg SO <sub>2</sub> eq.]	0.0410	0.0006	0.0005	0.0421
Eutrophication potential	[kg (PO <sub>4</sub> ) <sup>3-</sup> -eq.]	0.0040	0.0007	0.0001	0.0048
Formation potential of tropospheric ozone	[kg Ethene eq.]	0.0028	0.00	0.0021	0.0049
Abiotic depletion potential (ADP-elements) for non-fossil resources	[kg Sb eq.]	0.14	0.00	0.00	0.14
Abiotic depletion potential (ADP-fossil fuels) for fossil resources	[MJ]	227.5	1.13	4.4	233.1

Environmental aspects on resource use: 1 m <sup>2</sup>					
Indicator	Unit	A1	A2	A3	A1-A3
Use of renewable primary energy excluding renewable primary energy resources used as raw materials	[MJ]	INA	INA	INA	INA
Use of renewable primary energy resources used as raw materials	[MJ]	INA	INA	INA	INA
Total use of renewable primary energy resources (primary energy and primary energy resources used as raw materials)	[MJ]	1.05	0.00	0.34	1.38
Use of non-renewable primary energy excluding non-renewable primary energy resources used as raw materials	[MJ]	INA	INA	INA	INA
Use of non-renewable primary energy resources used as raw materials	[MJ]	INA	INA	INA	INA
Total use of non-renewable primary energy resources (primary energy and primary energy resources used as raw materials)	[MJ]	251.82	1.13	4.78	257.73
Use of secondary material	[kg]	0.71	0.00	0.00	0.71
Use of renewable secondary fuels	[MJ]	1.81	0.00	0.00	1.81
Use of non-renewable secondary fuels	[MJ]	2.49	0.00	0.00	2.49
Net use of fresh water	[dm <sup>3</sup> ]	3.90	0.01	0.75	4.66

Other environmental information describing waste categories: 1 m <sup>2</sup>					
Indicator	Unit	A1	A2	A3	A1-A3
Hazardous waste disposed	[kg]	0.002	0	0	0.002
Non-hazardous waste disposed	[kg]	0.99	0.0048	0.07	1.06
Radioactive waste disposed	[kg]	0	0	0	0
Components for re-use	[kg]	0	0	0.0007	0.0007
Materials for recycling	[kg]	0.09	0.001	0.012	0.103
Materials for energy recovery	[kg]	0	0	0	0
Exported energy	[MJ]	0	0	0	0

# ENVIRONMENTAL PRODUCT DECLARATION

**ATLAS ETICS**  
**EXTERNAL THERMAL INSULATION COMPOSITE SYSTEMS**  
**WITH SILICATE RENDERS**  
 in accordance with ISO 14025:2010 and EN 15804:2012



Table 12. Environmental characteristic for 1 m<sup>2</sup> of ETICS (silicate render), 15cm EPS

Environmental assessment information (MND – Module not declared, MD – Module Declared)																
Product stage			Construction process		Use stage							End of life			Benefits and loads beyond the system boundary	
Raw material supply	Transport	Manufacturing	Transport to construction site	Construction-installation process	Use	Maintenance	Repair	Replacement	Refurbishment	Operational energy use	Operational water use	Deconstruction demolition	Transport	Waste processing	Disposal	Reuse-recovery-recycling potential
A1	A2	A3	A4	A5	B1	B2	B3	B4	B5	B6	B7	C1	C2	C3	C4	D
MD	MD	MD	MND	MND	MND	MND	MND	MND	MND	MND	MND	MND	MND	MND	MND	MND

Environmental impacts: 1 m <sup>2</sup>					
Indicator	Unit	A1	A2	A3	A1-A3
Global warming potential	[kg CO <sub>2</sub> eq.]	14.8	0.1	0.3	15.2
Depletion potential of the stratospheric ozone layer	[kg CFC 11 eq.]	7.76E-07	5.66E-07	3.34E-09	1.35E-06
Acidification potential of soil and water	[kg SO <sub>2</sub> eq.]	0.0475	0.0006	0.0005	0.0486
Eutrophication potential	[kg (PO <sub>4</sub> ) <sup>3-</sup> -eq.]	0.0046	0.0007	0.0001	0.0054
Formation potential of tropospheric ozone	[kg Ethene eq.]	0.0032	0.00	0.0021	0.0053
Abiotic depletion potential (ADP-elements) for non-fossil resources	[kg Sb eq.]	0.16617	0.00	0.00	0.16617
Abiotic depletion potential (ADP-fossil fuels) for fossil resources	[MJ]	278.9	1.1	4.4	284.4

Environmental aspects on resource use: 1 m <sup>2</sup>					
Indicator	Unit	A1	A2	A3	A1-A3
Use of renewable primary energy excluding renewable primary energy resources used as raw materials	[MJ]	INA	INA	INA	INA
Use of renewable primary energy resources used as raw materials	[MJ]	INA	INA	INA	INA
Total use of renewable primary energy resources (primary energy and primary energy resources used as raw materials)	[MJ]	1.05	0.00	0.34	1.38
Use of non-renewable primary energy excluding non-renewable primary energy resources used as raw materials	[MJ]	INA	INA	INA	INA
Use of non-renewable primary energy resources used as raw materials	[MJ]	INA	INA	INA	INA
Total use of non-renewable primary energy resources (primary energy and primary energy resources used as raw materials)	[MJ]	308.37	1.13	4.78	314.27
Use of secondary material	[kg]	0.74	0.00	0.00	0.74
Use of renewable secondary fuels	[MJ]	1.81	0.00	0.00	1.81
Use of non-renewable secondary fuels	[MJ]	2.49	0.00	0.00	2.49
Net use of fresh water	[dm <sup>3</sup> ]	3.96	0.01	0.75	4.72

Other environmental information describing waste categories: 1 m <sup>2</sup>					
Indicator	Unit	A1	A2	A3	A1-A3
Hazardous waste disposed	[kg]	0.002	0	0	0.002
Non-hazardous waste disposed	[kg]	1.01	0.0048	0.07	1.08
Radioactive waste disposed	[kg]	0	0	0	0
Components for re-use	[kg]	0	0	0.0007	0.0007
Materials for recycling	[kg]	0.09	0.001	0.012	0.103
Materials for energy recovery	[kg]	0	0	0	0
Exported energy	[MJ]	0	0	0	0

# ENVIRONMENTAL PRODUCT DECLARATION

**ATLAS ETICS**  
**EXTERNAL THERMAL INSULATION COMPOSITE SYSTEMS**  
**WITH SILICATE RENDERS**  
 in accordance with ISO 14025:2010 and EN 15804:2012



Table 13. Environmental characteristic for 1 m<sup>2</sup> of ETICS (silicate render), 20cm EPS

Environmental assessment information (MND – Module not declared, MD – Module Declared)																
Product stage			Construction process		Use stage							End of life			Benefits and loads beyond the system boundary	
Raw material supply	Transport	Manufacturing	Transport to construction site	Construction-installation process	Use	Maintenance	Repair	Replacement	Refurbishment	Operational energy use	Operational water use	Deconstruction demolition	Transport	Waste processing	Disposal	Reuse-recovery-recycling potential
A1	A2	A3	A4	A5	B1	B2	B3	B4	B5	B6	B7	C1	C2	C3	C4	D
MD	MD	MD	MND	MND	MND	MND	MND	MND	MND	MND	MND	MND	MND	MND	MND	MND

Environmental impacts: 1 m <sup>2</sup>					
Indicator	Unit	A1	A2	A3	A1-A3
Global warming potential	[kg CO <sub>2</sub> eq.]	18.2	0.1	0.3	18.5
Depletion potential of the stratospheric ozone layer	[kg CFC 11 eq.]	8.15E-07	5.66E-07	3.34E-09	1.38E-06
Acidification potential of soil and water	[kg SO <sub>2</sub> eq.]	0.0583	0.0006	0.0005	0.0594
Eutrophication potential	[kg (PO <sub>4</sub> ) <sup>3-</sup> eq.]	0.0056	0.0007	0.0001	0.0064
Formation potential of tropospheric ozone	[kg Ethene eq.]	0.0038	0.00	0.0021	0.0060
Abiotic depletion potential (ADP-elements) for non-fossil resources	[kg Sb eq.]	0.21	0.00	0.00	0.21
Abiotic depletion potential (ADP-fossil fuels) for fossil resources	[MJ]	364.5	1.1	4.4	370.0

Environmental aspects on resource use: 1 m <sup>2</sup>					
Indicator	Unit	A1	A2	A3	A1-A3
Use of renewable primary energy excluding renewable primary energy resources used as raw materials	[MJ]	0.00	INA	INA	INA
Use of renewable primary energy resources used as raw materials	[MJ]	INA	INA	INA	INA
Total use of renewable primary energy resources (primary energy and primary energy resources used as raw materials)	[MJ]	INA	0.00	0.34	0.34
Use of non-renewable primary energy excluding non-renewable primary energy resources used as raw materials	[MJ]	INA	INA	INA	INA
Use of non-renewable primary energy resources used as raw materials	[MJ]	INA	INA	INA	INA
Total use of non-renewable primary energy resources (primary energy and primary energy resources used as raw materials)	[MJ]	402.61	1.13	4.78	408.52
Use of secondary material	[kg]	0.79	0.00	0.00	0.79
Use of renewable secondary fuels	[MJ]	1.81	0.00	0.00	1.81
Use of non-renewable secondary fuels	[MJ]	2.49	0.00	0.00	2.49
Net use of fresh water	[dm <sup>3</sup> ]	4.06	0.01	0.75	4.82

Other environmental information describing waste categories: 1 m <sup>2</sup>					
Indicator	Unit	A1	A2	A3	A1-A3
Hazardous waste disposed	[kg]	0.002	0	0	0.002
Non-hazardous waste disposed	[kg]	1.05	0.0048	0.07	1.12
Radioactive waste disposed	[kg]	0	0	0	0
Components for re-use	[kg]	0	0	0.0007	0.0007
Materials for recycling	[kg]	0.09	0.001	0.012	0.103
Materials for energy recovery	[kg]	0	0	0	0
Exported energy	[MJ]	0	0	0	0

## VERIFICATION

The process of verification of an EPD is in accordance with EN ISO 14025, clause 8 and ISO 21930, clause 9. After verification, this EPD is valid for a 5-year-period. EPD does not have to be recalculated after 5 years, if the underlying data have not changed significantly.

### The basis for LCA analysis was EN 15804

Independent verification corresponding to ISO 14025 & 8.3.1.



external



internal

Verification of EPD: dr eng. Aleksander Panek

LCI audit and input data verification: msc eng. Dominik Bekierski

LCA: dr eng. Michał Piasecki

Verification of procedures and declaration: dr eng. Halina Prejzner

## NORMATIVE REFERENCES

- ISO 14025:2006, Environmental management – Type III environmental declarations – Principles and procedure.
- ISO 21930:2007, Sustainability in building and construction – Environmental declaration of building products.
- ISO 14044:2006, Environmental management – Life cycle assessment – Requirements and guidelines.
- ISO 15686-1:2000, Buildings and constructed assets — Service life planning — Part 1: General principles
- ISO 15686-8:2008, Buildings and constructed assets – Service life planning – Part 8: Reference service life
- EN 15804:2012, Sustainability in construction works – Environmental product declarations – Core rules for the product category of construction products.
- EN 15942:2011, Sustainability of construction



**Instytut Techniki Budowlanej**

**Zakład Fizyki Ciepłej, Instalacji Sanitarnych i Środowiska**

02-656 Warszawa, ul. Ksawerów 21

# **ŚWIADECTWO nr 021/2014**

## **DEKLARACJI ŚRODOWISKOWEJ III TYPU**

Wyroby:

**Zestaw wyrobów do wykonywania ociepleń ścian zewnętrznych budynków  
systemem ATLAS ETICS z tynkiem silikatowym**

Wnioskodawca:

**ATLAS Sp. z o.o.**

91-222 Łódź, ul. Św. Teresy 105

potwierdza się poprawność ustalenia danych uwzględnionych przy opracowaniu  
Deklaracji Środowiskowej III typu oraz zgodność z wymaganiami normy

**PN-EN 15804:2012**

**Zrównoważoność obiektów budowlanych.**

**Deklaracje środowiskowe wyrobów.**

**Podstawowe zasady kategoryzacji wyrobów budowlanych.**

Niniejsze świadectwo, wydane po raz pierwszy 10 marca 2014 r. jest ważne 5 lat,  
lub do czasu zmiany wymienionej Deklaracji Środowiskowej

Kierownik  
Zakładu Fizyki Ciepłej,  
Instalacji Sanitarnych i Środowiska

Robert Geryto



Dyrektor  
Instytutu Techniki Budowlanej

Jan Bobrowicz

Warszawa, marzec 2014 r.



